

CHAPTER ONE

INTRODUCTION

1.1 Background of Study

The energy management system (EMS) for the Smart Campus Hybrid Microgrid (SCHMG) is a very important and major part of every hybrid microgrid, which takes care of energy management within the microgrid. It is in charge of harnessing all the available energy sources to the microgrid, making intelligent decision based on the available energy sources and distributing the energy to the loads intelligently. For the purpose of this study, a case of a campus solar-diesel hybrid microgrid for some selected Areas at Nnamdi Azikiwe University Awka Campus was studied. These selected areas are the School of Postgraduate Studies (SPGS), the Faculty of Law (LAW), the University Library (LIB) and the Faculty of Engineering (ENG). Each of these selected sites operates as an independent solar-diesel microgrid and are referred to as sub-grids. These four sub-grids can also supply energy to or receive energy from neighbouring sub-grids depending on their status. That is whether it has excess or it needs extra.

According to Gibin et al,(2016), a microgrid is a local and independent energy system that generates, distributes, stores and regulates the flow of electricity within the microgrid. It is essentially a miniature version of the main grid. It can draw energy from both renewable and non-renewable sources (Robert, et al., 2002). For microgrids to operate efficiently, the energy supplied from the energy sources must be properly managed by an EMS. It intelligently monitors the available energy sources and decides the loads that should be supplied and the ones that should be load-shaded in order to achieve the best management scheme based on the available resources. The EMS targets to supply reliable and steady power within the MG at the cheapest possible rate. It also decides when to engage the different sources available to the MG and how long they will run in order to achieve the most economic viable energy management. The EMS is in charge of general control and energy management within the MG. It manages the inputs to the MG, which come from the utility grid, solar-PV, diesel generators, and auxiliary power input (power from neighbouring sub-grid). The EMS also controls the supply of power to the different categories of the electrical loads within the MG. The energy management system runs with an algorithm that ensures the maximum power availability within the MG at the minimum running cost.

According to Longe et al, (2017), microgrid technology encourages Distributed Generation (DG). Distributed generation as contrast to bulk generation uses several renewable energy resources available to generate electricity at distributed locations. The locations can be supplied by majorly the energy generated in their location instead of totally relying on the National grid. More so, DG drastically reduces the pressure on the aging transmission grid infrastructure, which is one of the challenges the public power vendors are currently facing. Several renewable energy sources can be harnessed to supply a MG. The renewable energy sources used should be determined by the ones readily available and that can easily be harnessed at the MG location. Solar energy is readily available at Nnamdi Azikiwe University Awka campus and was used for the SCHMG.

Solar energy is one of the major renewable energy sources largely available in many countries like Nigeria (Latham and Watkins, 2016). This energy can be seen as free energy, as the only cost of generation lies on the installation of the components needed for energy conversions and storage. Solar-electric power can be produced either by steam turbine power plants using the sun's heat or by photovoltaic (PV) technology, which converts sunlight directly to electricity in form of direct current (dc) voltage using solar cells (Herzog, Lipman and Kammen, 2001). With any of these two methods, solar electricity can be generated in the day when solar energy is available. It can also be stored using energy storage devices to be used at night when solar energy is unavailable. The solar energy potential of Nigeria is more than enough to solve the problem of electricity in Nigeria if it is harnessed (Ilenikhan and Ezemonye, 2010). Nigeria receives an average solar radiation of about 7.0KWh/m^2 daily i.e, (25.2MJ/m^2) daily in the far north and 3.5kWh/m^2 daily i.e, (12.6MJ/m^2) daily in the coastal latitudes (Ilenikhan and Ezemonye, 2010). Nigeria is situated in the high solar radiation belt of the world. The estimate of potential solar energy in Nigeria with 5% device conversion efficiency is $5.0 \times 10^{14}\text{KJ}$ of useful energy annually (Ilenikhan and Ezemonye, 2010). This is equivalent to about 258.62 Million barrels of oil produced annually and about 4.2×10^5 GWh of electricity production annually in the country.

Therefore, smart campus solar-diesel hybrid microgrid is a viable approach to improving the availability of steady electricity in Nigerian universities. This microgrid will rely much more on the solar power input than the other power inputs. This will drastically cut down the cost of providing power to Nigerian universities.

Steady electricity is one of the vital tools to any nation's economic growth. It encourages industrialization as companies will not need to incur unnecessary extra cost in running diesel generators (Amos, Zekeri, and Idowu, (2017)). Small and medium Scale enterprises will comfortably thrive with steady electricity and that will increase employment opportunities, thus impacting positively on the nation's GDP (Oghogho, 2014). In addition, the universities, which are the main focus of study, will run their activities more efficiently and university education will become more affordable to the poor masses. The current high cost of university education in Nigeria is traceable to many factors including the high running cost of the university campuses of which the cost of providing electricity is a major contributor to this high running cost. Taking Nnamdi Azikiwe University(NAU) as a case study, monthly the cost of providing electricity takes about 40% of the total cost of running the university. This cost includes both the cost of buying diesel for the various diesel generators and the payment of electricity bills. Even with all these heavy expenses on electricity, it is still very difficult to realize steady power supply and this has impacted negatively on the research output of the University. Most students who may require steady power for their research experiments have to go outside to pay heavily in order to implement their researches, others that cannot afford the cost, are compelled to manipulate their research results, thereby negatively affecting the quality of research output.

In addition, due to the current challenges of the Nation's electricity supply, the national grid is not by any means reliable in terms of constant electricity supply. These challenges include, the aging transmission grid, the constant increase in electricity demand, the shutting down of some generation plants, the low capacity generation of some generating plants, poor metering of electricity, electricity theft, management challenges, to mention but a few (Etukudor, Ademola, Olayinka, 2015). These challenges make it near impossible for the existing system to solve the electricity challenge of the nation. Micro-grids are viable solutions to these noted challenges. This is because they will integrate distributed generation from renewable resources into the system and will drastically reduce the stress on the main grid. With distributed generation, individuals, universities and companies can generate and manage the bulk of the electricity they need from available renewable resources, drastically reducing their dependence on the main grid. This is the idea behind the smart campus solar-diesel hybrid microgrid. This microgrid design integrates distributed solar energy generation into the existing electricity system of the target sites. The solar energy is the primary source of

power to the microgrid; the diesel generator and the main grid serve as backup power sources, in the event of cloudy weather conditions or routine maintenance.

1.2 Problem Statement

Energy cost are the second largest operating expenses for many Nigerian Universities; the high cost of electricity provision in Nigerian Universities by majorly depending on running diesel generators cannot be over emphasized. This has drastically increased the of cost education in Nigerian tertiary institutions. The National electricity grid is not an option at all as it is very unreliable and unpredictable.

In addition, most researches that students at different levels of learning are required to conduct need uninterrupted power supply to be successful and that is very far from the reality in most Nigerian Universities. That has led to poor research results from several Nigerian Universities and heavy expense enquired by out sourcing such research to places with the required uninterrupted electricity.

Microgrid is a key pillar of the 21st century electric grid envisioned by the Smart Grid Research and Development. Smart MG power system comprises of parallel connected Distributed Energy Resources (DERs), with electronically controlled strategies, which are capable of operating in both island and grid connected modes. The DERs include but not limited to solar energy, wind energy, biomass, fuel cells e.t.c. The intermittence of these renewable energy sources, makes managing the power balance and reliability (stability) of MGs a difficult task; another major objective of this research is to develop and simulate an energy management architecture that enables multiple MGs to operate independently or in an active interconnected mode reliably.

1.3 Aim and Objectives

The aim of this research is to develop an Energy Management System (EMS) that maximizes the use of non-conventional energy sources (solar PV) in a Smart Campus Hybrid Microgrid (SCHMG) while minimizing the total energy cost.

Specific Objectives include;

- (a) To carry out a comprehensive electrical load estimation of the installed electrical loads at the different sub-grids.
- (b) To carry out cost analysis of the electric energy supply to the different sub-grids by conventional energy sources (of diesel generators and public utility grid coming from the 11kV line from Agu-Awka Injection substation), and compare with the cost of running the SCHMG.
- (c) To design and optimally dimension hybrid energy sources for the multiple sub-grids using the Hybrid Optimization Model for Electric Renewables (HOMER) grid software.
- (d) To develop an intelligent agent model termed Local Intelligent Agent (LIA) for energy management at the different sub-grids and control algorithm that enables the interconnection of multiple sub-grids.
- (e) To implement the LIA energy scheduling algorithm using fuzzy logic.
- (f) To implement and simulate the Fuzzy model in MatLab/Simulink using fuzzy logic controller.
- (g) To evaluate the performance of the EMS developed, by comparing the actual simulated system response to the expected system response.

1.4 Justification for the Research Work

The energy management system of the SCHMG is what makes the MG intelligent; therefore, the SCHMG cannot deliver the desired objectives without a smart energy management system. Thus to achieve the desired objectives, there is need for the incorporation of a smart energy management system, which ensures the proper management of energy within the target sub-grids. It is a known fact that no matter how much energy generated, if not properly managed; it will be wasted or misused, resulting into system failure.

The positive impact of this research will go a long way in achieving power stability on campus thereby improving research outputs, and hopefully minimizing the exorbitant fees students pay. Leveraging on smart monitoring and control that was employed in the development of the energy management system, the wastage of available energy was minimised drastically, while still delivering reliable power supply to categorised loads. That is, the losses were reduced to the barest minimum. Besides, the SCHMG will contribute also to the economic growth of the Nation as the deployment of the system in various university campuses will create employment for many Nigerians. The result of this research work when

commercialized can be exported to other nations of the world especially the developing Nations having similar power challenges in their university campuses.

1.5 Scope of Work

This work is focused on modelling and simulation of an EMS used to manage the energy within the different sub-grids of the SCHMG and that can be readily deployed to manage energy in any other microgrid or minigrid setups. The Hybrid Optimization Model for Electric Renewables (HOMER) Grid software was used to model and simulate each sub-grid. It was also used to dimension the required component of each of the sub-grid. The cost implication of setting up and running of these sub-grids were also presented. In addition, analysis carried out gave the specifications of the each sub-grid's the system requirements.

CHAPTER TWO

LITERATURE REVIEW

2.1 Microgrid Technology

Llanos, et al. (2017) and Mozafari (2016) defined a microgrid as a local energy network, offering integration of Distributed Energy Resources (DER) with local elastic loads, which can operate in parallel with the main grid or in an intentional island mode to provide a customized level of high reliability and resilience to grid disturbances. This advanced, integrated distribution system addresses the need for application in locations with electric supply and/or delivery constraints, in remote sites, and for protection of critical loads and economically sensitive development. Mozafari (2016) defined a micro grid as a group of interconnected loads and distributed energy resources within clearly defined electrical boundaries that acts as a single controllable entity with respect to the main grid. The micro-grid should be able to connect and disconnect from the main grid to enable it to operate in both grid-connected or island-mode. According to Fikari (2015), the major features of a micro-grid are as follows;

- Ability to operate in both island and grid-connected modes.
- It appears as a single controlled entity to the main grid.
- It intelligently combines interconnected loads and the distributed power generation sources (that is, ability to manage the available energy to supply designated loads).
- Provision of high levels of power quality and reliability for end-uses.
- Designed to accommodate total system energy requirements.
- Smart energy management to provide most reliable and stable power supply, while leveraging on renewables to minimize the total cost operation.

2.1.1 The Microgrid Structure

The Microgrid structure assumes an aggregation of loads and Distributed Energy Resources (DERs) (which majorly should be renewable energy sources) operating as a single system providing both power and cooling as the case may be (Swaminathan Ganesan, 2017). The required flexibility in the control of DERs is provided via power electronics interfaced with embedded systems. Therefore, the DERs must be power electronic based or compatible with power electronic components. This enhances the ease of integration and control of the different DERs that make up the micro-grid, thus enabling the resulting micro-grid to be controlled and operated as a single aggregate system. This control flexibility is what makes

the system smart and allows the micro-grid to present itself to the bulk power system as a single controlled unit. Each DER unit is integrated together in a plug-and-play fashion to meet the customers' local needs (Goyal, Arindam and Firuz, 2013). These needs include increased local reliability, cost-effectiveness, steady power availability and security. The major components of a micro-grid structure include the interface, control and protection requirements for each DER as well as micro-grid voltage control, power flow control, intelligent load sharing during intentional islanding, intelligent load shedding if need be, stability, and over all operation (Ernie, 2013). The ability of the microgrid to operate in a grid connected mode as well as smooth transition to and from the island mode is another very important feature of the microgrid technology, and this is made possible by the EMS.

(Ernie, 2013) Presented the classification of MG based on the purpose for which they are put to use. Several categories of MG were identified, namely, Campus Environment/Institutional MGs, Remote "Off-grid microgrids", military base microgrids, Commercial and Industrial (C and I) microgrids, Community/Utility microgrids.

2.1.1.1 Campus Environment/Institutional Microgrids

As the name suggests, it has to do with microgrids located within a campus or institutional settings. The major focus of campus micro-grids is to harness all the existing on-site power generation systems like diesel generators, main grid power system e.t.c, and integrate them with available renewable energy resources, so as to intelligently distribute the available energy to the target loads, in order to deliver a very reliable, cost effective and efficient system. The size of DERs in Campus micro grid can range from less than 4 Megawatts (MW) to more than 40 MW as the case may be Ernie (2013).

2.1.1.2 Remote "Off-grid" Microgrids

These are micro-grid located in remote areas where the main grid is not accessible. These microgrids are never connected to the main grid; instead they continuously run in an island mode (Longe, Rao, Omowole, Oluwalami and Oni, 2017). Their sizes depend on the capacity of the load they are delivering power to. Remote off-grid microgrid is very useful in locations where it is difficult or impossible to extend the utility grid to. However, individuals and companies may on their own disconnect from the utility grid and use an off-grid microgrid system.

2.1.1.3 Military Base Microgrids

These micro grids are being actively deployed with focus on both physical and cyber security for military facilities in order to assure reliable power without relying on the main grid (Longe, Rao, Omowole, Oluwalami, and Oni, 2017). This micro-grid class are designed with very high precision with respect to reliability and security. They are meant to be rugged as several times they are deployed in harsh military terrains. Military microgrids are designed to be very sustainable as they are used to supply very critical electrical loads and military gadgets.

2.1.1.4 Commercial and Industrial (C and I) Microgrids

These types of microgrids are specifically designed for industrial and commercial applications (Ernie, 2013). They are designed to the specifications of the target industrial or commercial outfits. The major motivation towards their design is to increase profitability, by reducing the cost of provision of energy to the lowest possible amount. A typical example of such microgrid designs are microgrids designed and deployed to provide power to hospitals, research institutions, production companies e.t.c. Several companies shy away from implementing such C and I microgrids due to its initial capital intensive nature. However, when implanted, such companies succeed in saving much more at the long run, than they have invested.

2.1.1.5 Community/Utility Microgrids

These are microgrid designed with respect to a community's utility need (Ernie, 2013) and (Fikari, 2015). They can be off-grid or utility grid connected depending on the design specifications of the MG. The specifications of their designs are based on the community's energy demand.

2.1.1.6 Hybrid Microgrids

Hybrid microgrids are microgrids that have more than one form of input power sources integrated together to supply the microgrid (Sakthivel and Devaraji, 2015). Examples of hybrid microgrids are, hybrid solar-wind microgrid, hybrid solar-diesel micro-grid e.t.c. Hybrid micro grids are much more efficient than MGs that are based on one energy source. This high efficiency is achieved from the proper management of various energy sources to

the MG. In such MGs, the percentage power outage is very minimal, and the stability of the entire microgrid is always very high.

2.2 Reviews on Principles and Concepts

Several principles and concepts were considered to be used for the work; however two were finally adopted. These were, the fuzzy logic principle and the concept of intelligent agents. The fuzzy Logic principle was adopted for the modelling of the EMS, while the concept of intelligent agents was used for the implementation. In the actual sense, fuzzy logic was used to model the intelligent agents responsible for the SCHMG energy management system..

2.2.1 Fuzzy Logic

Fuzzy logic is a convenient way to map an input space to an output space. Mapping input to output is the starting point for everything (Al-Odienat and Al-Lawama, 2008). Though fuzzy logic maps inputs to outputs, it works with several simple fuzzy rules provided to take several complex decisions as it gives its output. Fuzzy logic has two different meanings. In a narrow sense, fuzzy logic is a logical system, which is an extension of multi-valued logic. Unlike discrete logic where there are discrete and précised points (that is either 1 or 0, HIGH or LOW), fuzzy logic gives output based on degree of membership. For example instead of just having HIGH or LOW, it will have VERY HIGH, HIGH, LOW and VERY LOW states, this corresponds to the range of possible points between 0 and 1. In a wider sense fuzzy logic (FL) is almost synonymous with the theory of fuzzy sets, a theory which relates to classes of objects with un-sharp boundaries in which membership is a matter of degree (Albertos and Antonio, 1998). Even in its more narrow definition, fuzzy logic differs both in concept and substance from traditional multi-valued logical systems. In recent years, the number and variety of applications of fuzzy logic have increased significantly. The applications range from consumer products such as cameras, camcorders, washing machines, and microwave ovens to industrial process control, medical instrumentation, decision-support systems, and portfolio selection (Gupta, 2017)

2.2.1.1 Fuzzy Logic Tool Box in MATLAB

Fuzzy Logic Toolbox provides MatLab functions, applications, and a Simulink block for analyzing, designing, and simulating systems based on fuzzy logic (Costa, Clauber, and Luiz, 2012) and (MathWorks, 2018). The product guides on the steps of designing Fuzzy Inference Systems (FIS). Functions are provided for many common methods, including fuzzy clustering and adaptive neuro-fuzzy learning. The toolbox lets you model complex system

behaviours using simple logic rules, and then implements these rules in a fuzzy inference system (MathWorks, 2018). You can use it as a stand-alone fuzzy inference engine. Alternatively, you can use fuzzy inference blocks in Simulink and simulate the fuzzy systems within a comprehensive model of the entire dynamic system.

The key features of MatLab in the fuzzy logic tool box are as given below:

- Fuzzy Logic Design application for building fuzzy inference systems (FIS) and viewing and analyzing results
- Membership functions for creating fuzzy inference systems.
- Support for AND, OR, and NOT logic in user-defined rules.
- Standard Mamdani and Sugeno-type fuzzy inference systems.
- Automated membership function shaping through neuro adaptive and fuzzy clustering learning techniques.
- Ability to embed a fuzzy inference system in a Simulink model.
- Ability to generate embeddable C-language code or stand-alone executable fuzzy inference engines.

Another basic concept in Fuzzy Logic, which plays a central role in most of its applications, is that of a fuzzy if-then rule or, simply, fuzzy rule (Chevrie and Guely, 1998). Although rule-based systems have a long history of use in Artificial Intelligence (AI), what is missing in such systems is a mechanism for dealing with fuzzy consequents and fuzzy antecedents (Chevrie and Guely, 1998). In fuzzy logic, this mechanism is provided by the calculus of fuzzy rules. The calculus of fuzzy rules serves as a basis for what might be called the Fuzzy Dependency and Command Language (FDCL). Although FDCL is not used explicitly in the toolbox, it is effectively one of its principal constituents.

In most of the applications of fuzzy logic, a fuzzy logic solution is, in reality, a translation of a human solution into FDCL (Umarikar, 2003). A trend that is growing in visibility relates to the use of fuzzy logic in combination with neuro-computing and genetic algorithms. More generally, fuzzy logic, neuro-computing, and genetic algorithms may be viewed as the principal constituents of what might be called soft computing. Unlike the traditional, hard computing, soft computing accommodates the imprecision of the real world. The guiding principle of soft computing is: exploit the tolerance for imprecision, uncertainty, and partial truth to achieve tractability, robustness, and low solution cost (Das, Kumar, Das, and Burnwal 2013). In the future, soft computing could play an increasingly important role in the

conception and design of systems whose Machine IQ (MIQ) is much higher than that of systems designed by conventional methods.

Among various combinations of methodologies in soft computing, the one that has highest visibility at this juncture is that of fuzzy logic and neuro-computing, leading to neuro-fuzzy systems. Within fuzzy logic, such systems play a particularly important role in the induction of rules from observations. An effective method developed by Dr. Roger Jang for this purpose is called Adaptive Neuro-Fuzzy Inference System (ANFIS) (MathWorks, 2018). This method is an important component of the toolbox. Fuzzy logic is all about the relative importance of precision. Fuzzy Logic Toolbox software with MatLab technical computing software can be used as a tool for solving problems that has to do with fuzzy logic. Fuzzy logic is a fascinating area of research because it does a good job of trading off between significance and precision — something that humans have been managing for a very long time. In this sense, fuzzy logic is both old and new because, although the modern and methodical science of fuzzy logic is still young, the concepts of fuzzy logic relies on age old skills of human reasoning (MathWorks, 2018).

2.2.1.2 Fuzzy Logic Controllers

Fuzzy logic controllers in Simulink are used to implement, simulate and obtain results from fuzzy logic models. Using these controllers, one can view, analyse and make deductions on a simulation model. Figure 2.1 shows a general structure of fuzzy logic controllers (Gaurav and Kaur, 2012).

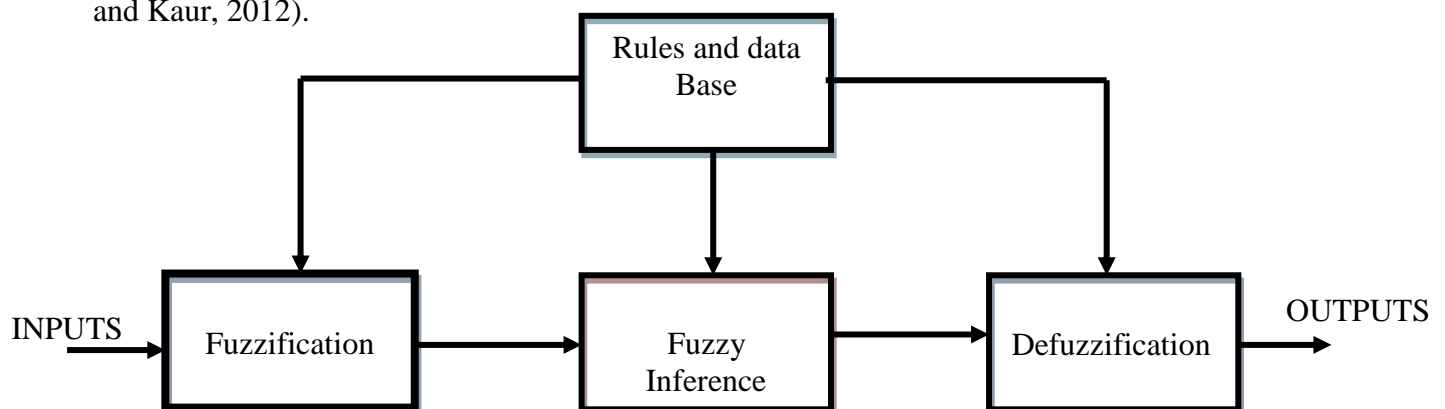

Figure 2.1 General Structure of Fuzzy Logic Controllers (Gaurav and Kaur, 2012)

In figure 2.1, the fuzzification is the process of arranging the inputs with reference to the rules provided. The fuzzy inference block makes inference based on the provided rules, while the outputs are released by the process of defuzzification (Naderii, Ghasemzadehii, Pourazar,

and Aliasgharyii, 2009). Thus the inputs are mapped to the outputs based on the fuzzy rules provided.

The advantages of modelling complex systems with fuzzy logic inference system (FIS) cannot be overemphasized. According to (Sugeno and Yasukawa, 1993) and (Farouk and Sheng, 2012) here are list of general observations about fuzzy logic that makes it an excellent modelling approach for very complex non-precision systems:

- Fuzzy logic is conceptually easy to understand.

The mathematical concepts behind fuzzy reasoning are very simple. Fuzzy logic is a more intuitive approach without the far-reaching complexity.

- Fuzzy logic is flexible. With any given system, it is easy to layer on more functionality without starting again from scratch.
- Fuzzy logic is tolerant of imprecise data. Everything is imprecise if you look closely enough, but more than that, most things are imprecise even on careful inspection. Fuzzy reasoning builds this understanding into the process rather than tacking it onto the end.
- Fuzzy logic can model nonlinear functions of arbitrary complexity. You can create a fuzzy system to match any set of input-output data. This process is made particularly easy by adaptive techniques like Adaptive Neuro-Fuzzy Inference Systems (ANFIS), which are available in Fuzzy Logic Toolbox software.
- Fuzzy logic can be built on top of the experience of experts. In direct contrast to neural networks, which take training data and generate opaque, impenetrable models, fuzzy logic lets you rely on the experience of people who already understand your system.
- Fuzzy logic can be blended with conventional control techniques. Fuzzy systems do not necessarily replace conventional control methods. In many cases fuzzy systems augment them and simplify their implementation.
- Fuzzy logic is based on natural language. The basis for fuzzy logic is the basis for human communication. This observation underpins many of the other statements about fuzzy logic. Because fuzzy logic is built on the structures of qualitative description used in everyday language, fuzzy logic is easy to use. The last statement is perhaps the most important one and deserves more discussion. Natural language, which is used by ordinary people on a daily basis, has been shaped by thousands of years of human history to be convenient and efficient. Sentences written in ordinary language represent a triumph of efficient communication.

2.2.2 Intelligent Agents

According to Khosravi (2011), an agent is anything that can be viewed as perceiving its environment through sensors and acting upon its environment through actuators. Also, Rovatsos (2016) pointed out that agents perceive their environments through sensors, and then achieve a preset goal by acting on their environment through actuators. A very good example of an agent is the human agent, that perceives their environment through their eyes, ears, and other sense organs (representing sensors), and achieve their set goals using their hands, legs, mouth, and other body parts, which represents actuators. Agents can also be seen as a mapping between percept sequences and actions (Russell and Norvig, 2016). This simply means that agents can receive inputs (perceive) through their sensors, take certain control decision based on their set goals, and deliver the expected outputs through their actuators or effectors.

Russell and Norvig, (2016), identifies four classes of intelligent agents namely; simple reflex agents, goal-based agents, utility-based agents and learning agents. From the classification above, the intelligent agent class that satisfies the proposed LIA is the utility-based agent, however, it will possess some attributes of the reflex and the goal-based agent. The works of Hurwitz and Marwala, (2007) introduced multi-agent modelling for games. In their opinion, it is easier to break down a very complex theory into smaller units that can be managed by multiple intelligent agents. In the resulting system, each agent will be dedicated to execute a specific task and by this method the complexity of modelling one complex system will be reduced to the modelling many simple agents.

In addition, Burgin and Dodig-Crnkovic, (2009) introduced artificial agents, in their view Agents are advanced tools people use to achieve different goals and to solve various problems. The main difference between ordinary tools and agents is that agents can function more or less independently from those who delegated agency to the agents. For a long time people used only other people and sometimes animals as their agents. Developments in information processing technology, computers and their networks, have made it possible to build and use artificial agents. Intelligent agents form a basis for many kinds of advanced software systems that incorporate varying methodologies, diverse sources of domain knowledge, and a variety of data types.

The intelligent agent (IA) approach has been applied extensively in business applications, and more recently in medical decision support systems (Hsu and Goldberg, (1999) and Lanzola, Gatti, Falasconi, and Stefanelli, (1999)). Apart from the noted applications, intelligent agents can be applied in the EMSs for MGs. In this unique application, their set goal will be to manage the available energy inputs to the MG, and deliver a steady supply of power at the cheapest possible running cost. Neumaier, (2016) viewed intelligent agents as a machine designed to perform work helpful to its owners. Agents can perform their dedicated goals automatically and intelligently without any human assistance or supervision. Intelligent agents seek to achieve what humans can do exactly the way they would have done them. An intelligent agent can be a hardware agent or a software agent.

Generally, an agent needs a hardware in which it is embodied, and software to enable it to respond appropriately to the environment which it lives in. In addition, Frankovič and Oravec, (2005) introduced the possibilities of multi-agent system application for the modelling and intelligent control in the case of coarse ceramics burning process. It consists of technological description of this process, its decomposition into agents and macro-model of the decision system. This application is closely related to the EMS in view because the LIA will also take care of the intelligent control and energy managements of the proposed MG. It is meant to take appropriate decisions based on the received inputs ensuring the proper management of the available energy sources, in order to deliver a steady, cost effective and reliable electric power supply to the MG.

2.2.2.1 Intelligent Agents in Electric Power Control Application

The application of intelligent agents in the control of electricity is growing drastically. This is because before now most controls in the power sector were manually done by humans. Figure 2.2 shows the manual data acquisition and control of electric feeders at Nibo substation in Awka south local government Area of Anambra State.

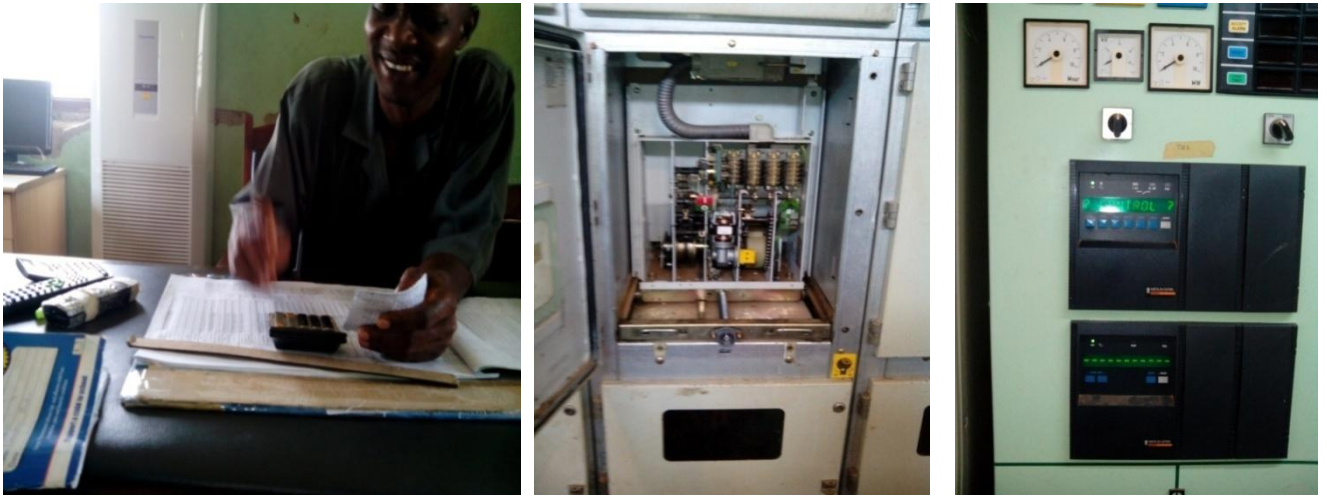

Figure 2.2: Manual feeder control and data acquisition at NIBO substation by a Staff.

This level of intelligence and control can only be mimicked by intelligent agents. For example, the scenario in figure 2.2 can comfortably be handled by an intelligent agent, that will monitor the power lines, log data acquired and make decision on when to handle feeder control. The authors in Wooldridge, (2009) and Xu, Gordon, Lind, and Ostergaard, (2009) presented the requirement analysis for autonomous systems and intelligent agents in future Danish Electric power system. They opined that an intelligent agent is an encapsulated computer system that is situated in some environment and can act flexibly and autonomously in that environment to meet its designed objectives. Intelligent Agents are autonomous and can exercise control over their state and behaviour; they are proactive and can take initiatives by themselves rather than passively responding to changes in their environment. Just like humans, intelligent agents are social and can communicate in high level dialogues.

In addition, intelligent agents can be seen as autonomous systems which can react intelligently and flexibly on changing operating conditions and demands from the surrounding processes (Rehtanz, 2003). Such intelligent and autonomous systems provide capabilities like decomposition, reasoning, dynamic, flexibility (dynamic reconfiguration) and cooperation modelling. These qualities make intelligent agents a very viable option in innovative control architectures in electric power systems (Saleem, Heussen, and Morten, 2009). More so, intelligent agents are considered appropriate for applications that are modular, decentralized, changeable, and complex (Wemstedt and Davidsson, 2002). The requirements for electric power control are completely met by the abilities of intelligent agents and so they are viable application that can help translate manual electric power controls to intelligent automatic controls. In addition, Smathers and Goldsmith, (2001), presented agent concept for intelligent distributed coordination in the Electric power grid.

They opined that intelligent agents and multi-agent systems promise to take information management for real-time control of the power grid to a new level. In their report, concept for intelligent agents mediating and coordinating communications between Control Areas and Security Coordinators for real-time control of the power grid was presented. Catterson, Davidson, and McArthur, (2012) presented practical applications of multi-agent system in electric power systems. They pointed out that to translate the current status of energy networks from passive to active system requires the embedding of intelligence within the network, and one of the most suitable approaches to achieve this is by the use of intelligent agent concept.

2.2.3 Deduction from Reviewed Principles

From the literatures reviewed so far on fuzzy logic and intelligent agents, it is clear that the combination of these two principles are best suitable for the implementation of the smart energy management system for the smart campus hybrid microgrid. According to Wooldridge M. , (2003), an intelligent agent is one that is capable of flexible autonomous action in order to meet its design objectives. The LIA should meet the three basic criteria;

- **Reactivity:** The LIAs should be able to perceive their environment via dedicated sensors, and respond in a timely fashion to changes that occur in it in order to satisfy their design objectives;
- **Pro-activeness:** The LIAs should be able to exhibit goal-directed behaviour by taking the initiative in order to satisfy their design objectives;
- **Social ability:** The LIAs should be able to interact with other LIAs (and possibly humans) in order to satisfy their design objectives (Wooldridge, M., 1999).

The intelligent agent concept will enable the resulting LIA to be flexible enough to take appropriate control decision without human interference. In addition, the fuzzy logic principle will be used to model the intelligence of the intelligent agent.

2.3 Review of Related Literatures

2.3.1 Microgrid Energy Management Systems (EMS)

The authors of Ganesan, (2017) worked on a robust energy management solution which will facilitate the optimum and economic control of energy flows throughout a microgrid network. They opined that the increased penetration of renewable energy sources is highly intermittent in nature as most renewable sources vary in their availability with time. Thus the energy

management system must be such that will take care of the intermittent nature of renewable energy sources used by microgrid and make arrangement on how to cushion the effect of this variation without affecting the stability and reliability of the MG negatively. Their EMS architecture enables precise management of power flows by forecasting of renewable energy generation, estimating the availability of energy at storage batteries, and invoking the appropriate mode of operation, based on the load demand to achieve efficient and economic operation. The predefined mode of operation is derived out of an expert rule set and schedules the load and distributed energy sources along with utility grid. In addition, to enable the proper management of the available energy, the load within the microgrid was sub-divided into three categories namely; Secure Critical (SC), Non-Secured Critical (NSC) and Non-Critical Loads (NCL). The SC are loads that must be kept running at all cost in the micro-grid, power interruption to these could be life threaten. The right application of these loads is to supply them through an uninterrupted power supply system. On the other hand, the NSC load are next in the rank of priority, they are meant to always be supplied, except when the grid is totally down and there is other option. The NCL may or may not be supplied, depending on the status of the microgrid. This energy management algorithm deployed is excellent, however, due to the introduction of several controls and switching points within their design, the resulting energy management system is susceptible to failure and thereby making the microgrid inefficient.

Lee, Shi, Gadh, and Kim (2016) evaluated microgrid management and control with an implementable Energy Management system. In their submission, they pointed out that a microgrid is usually characterized by its integration of distributed energy resources (DERs) and controllable loads. Such integration brings unique challenges to the microgrid management and control, which can be significantly different from conventional power systems. Therefore, a conventional Energy Management System (EMS) needs to be re-designed with consideration of the unique characteristics of MG. To this end, a microgrid EMS named Microgrid Platform (MP) was developed. The MP is meant to take into accounts all the functional requirements of a Microgrid EMS, that is, forecasting, optimization, data analysis, and human-machine interface, and also address the engineering challenges; that is, flexibility, extensibility and interoperability (Lee, Shi, Gadh, and Kim 2016) and (Zhao 2012).

Experiments conducted by deploying the prototype system to evaluate the MG managements and control in real-life setting showed that the MP was capable of managing the various devices in the test bed, interact with external systems and perform energy scheduling and demand response. Their work was great and showed the beauty of EMS in a microgrid. However, because of the use of prototype and very miniature components of the envisaged system, several real time aspect of the envisaged system could not be accurately tested and the assumptions made may not actually represent the real life EMS being demonstrated. Modelling and simulation would have been a better approach since the real life conditions of the modelled system can be characterized and simulated in order to get the actual system response.

Logenthiran, Srinivasan, and Khambadkone (2011) implemented a multi-agent system for grid energy management. They opined that there has to be drastic changes in grid control, since the electric grid is currently undergoing drastic changes too. The evolution of the smart utility grid and smart MG technology has brought several new challenges to electric power and electric power management. The electric grid is evolving, from what used to be a centralized structure to an entirely decentralized one. These changes are mainly due to the massive development of Distributed Renewable Energy Sources (DRES). This evolution toward what is now called the smart grid requires new control and energy management methods (Amini, Nabi, and Haghifam, 2013). These methods must be able to withstand new requirements, such as the highly distributed nature of the grid, the ability for part of the grid (microgrid) to run in island or connected modes and the varying nature of the Renewable Energy Sources (RESs).

Multi-Agent Systems (MAS) have characteristics that meet these requirements, in contrary to classical analytical and manual methods: the grid is considered as a collection of simple entities called agents corresponding to power sources, loads and other components, evolving in a given environment. A certain degree of distributed or collective intelligence can be achieved through the interaction of these agents with each other, cooperating or competing to reach their goals. The agents are given dedicated duties and they monitor to ensure that their duties are fully executed. These agents are saddled with the responsibility of taking care of the different parts of the MG. Each of these agents has their operational algorithm which controls their operation and they work together to deliver the highest degree of energy management and smart grid control. The agents responsible for the different sources wait for

the agents controlling power inputs to the MG to prompt them to supply, while the load shedding agents also expects signal from the control agent before they begin to load shed. In this way a very smart energy management system is achieved.

However, the shortfall of this system is the use of many agents instead of an intelligent agent; the number of agents makes the entire system susceptible to failure. For instance, if the controlling agents responsible for prompting the load shedding agents to load-shed fail to do so for any reasons, the load shedding agents will not load-shed even when there is a serious load shedding need, hence, this definitely will shut down the entire MG eventually. Adding, the multiple agents make trouble shooting in the event of system failure very difficult. This could lead to unnecessary microgrid down time. In the Smart EMS for the Smart Campus Hybrid Microgrid, an intelligent agent called Local Intelligent Agent (LIA) with multiple functions was adopted. The LIA was modelled with fuzzy logic algorithm and is able to smartly take up all the duties of the multiple agents. In event of any system failure, it is easier to trouble shoot and restore the entire system back to perfect operation, thereby preventing unnecessary downtime and increased running cost.

According to Bih (2006), fuzzy logic technique enables the implementation of very complex control algorithm by using very simple rule sets. Arcos-Aviles, Pascual, Marroyo, Sanchis, and Guinjoan (2018) presented the design of a low complexity energy management system using Fuzzy logic Controller of only 25-rules for a residential grid connected microgrid including renewable Energy sources and storage capability. The EMS assumes that neither the renewable generation nor the load demand is controllable, hence the reason for employing fuzzy logic technique. The main goal of the design is to minimize the microgrid power profile fluctuations while keeping the battery State of Charge (SoC) within specified limits. Instead of using forecasting-based methods, this approach uses both the microgrid energy rate-of-change and the battery SoC to increase, decrease or maintain the power delivered/absorbed by the mains. Hence the EMS increases its consumption from the mains if the battery SoC is reducing, so as to allow the battery time to recharge, while it reduces its consumption from the mains when the battery SoC is increasing. The fuzzy controller ensures that there is a balance between the battery SoC, the renewable resources and the mains supply. The controller design parameters (membership functions and rule-base) were adjusted to optimize a pre-defined set of quality criteria of the microgrid behaviour. A comparison with other EMS designs seeking the same goal was presented at simulation level, whereas the features

of this design were experimentally tested on a real residential microgrid implemented at the Public University of Navarre (Arcos-Aviles, Pascual, Marroyo, Sanchis, and Guinjoan 2018). This work is closely related to the EMS, for SCHMG, however, the emphasis of the model was only on the battery State of Charge (SoC), whereas the SCHMG, takes cognisance of SoC, public utility grid status and diesel generator status. Therefore, the EMS for the SCHMG model will definitely deliver a more steady and reliable power supply to its loads at the minimal cost.

Furthermore, Ruban, Rajasekaran, and Rajeswari (2015) designed an Energy Management System for hybrid microgrid consisting of PV generation, Battery Energy Storage System (BESS) and Wind Energy Conversion System (WECS) using fuzzy logic control. The battery acted as a storage system, and the Energy Back-up (EB) system acted as a stand-by source, this source was committed during the power failure condition. The Energy Management System incorporated the fuzzy logic control, which was used to achieve the optimization and distributed energy generation. The main operation of this Energy Management System was that of committing the energy sources, and battery management. In the case of the battery management, the fuzzy logic algorithm controlled the State of Charge (SoC) parameters of the battery. In this work, an energy management system was modelled using fuzzy logic algorithm; however, it was more concerned about just the battery State of Charge (SoC), which is just one of the parameters being monitored in the EMS for the SCHMG. The EMS for the SCHMG checks the batteries SoC, the utility grid status, the diesel generator status and the auxiliary power status and takes specific decisions based on their states.

Garrab, Bouallegue, and Bouallegue (2017) implemented a fuzzy logic controller that efficiently managed loads in a grid operated microgrid. This energy management system coordinated the flow of energy from inputs of the microgrid, which included the PV system with Maximum Power Point Tracking (MPPT) controller, the Battery Energy Storage System (BESS) with bulk converter and utility grid, to the critical and non-critical loads. The fuzzy logic based energy management system takes decisions based on the available input source and their status. The loads supplied, depended on the status of the input power sources being used. Here again, fuzzy logic energy management algorithm was focused on the flow of energy from the utility grid, rather than managing the entire energy resource available to the microgrid.

Roine, Therani, Manjili, and Jamshidi (2014) presented a microgrid energy management system using fuzzy control. In their work, they modelled the energy management system to monitor the load demand, cost of utility grid energy and the available energy within the microgrid. The EMS bought more energy from the utility grid if the energy demand exceeded the available energy within the microgrid, and the cost of energy was cheap at the time of the demand. However, in this model, critical loads were not considered, since the system may shutdown if the energy demand is higher than the available energy produced within the microgrid and the cost of energy is very high. The model did not make any provision for intelligent load shedding during shortage of energy within the microgrid.

Teo, Logenthiran, Woo, and Abidi (2016) presented a fuzzy logic control of Energy Storage System (ESS) in a hybrid Solar-PV/wind Microgrid. The modelled fuzzy logic energy management system that monitored the renewable power generated from the two Renewable Energy Resources (RES) (P_{res}). ($P_{balance}$) is the excess or shortage of power between power demanded by the load (P_{load}) and Power generated by the RES (P_{res}). This difference was met by the charging or discharging of the ESS as the case may be. The power available at the ESS is P_{ess} . $P_{balance}$ also corresponded to the power profile without an ESS. The remaining power is absorbed/injected back into the microgrid (P_{mgrid}). In this way the fluctuation of P_{mgrid} was minimized and cushioned by the ESS.

Mathematically,

$$P_{res} = P_{pv} + P_{wind} \quad (2.1)$$

$$P_{balance} = P_{load} - P_{res} \quad (2.2)$$

Also

$$P_{mgrid} = P_{balance} + P_{ess} \quad (2.3)$$

However, the serious attention must be paid to the ESS State of Charge (SoC). The State-of-Charge (SoC) represents the current capacity of the ESS with respect to its full capacity in percentage; 0% is fully discharge and 100% is fully charged (Spotnitz 2003). The SoC can be estimated from the expression in (2.4). Capacity fade refers to the loss of discharging capacities over time and life cycle refers to the number of charging/discharging cycles before reducing its capacity to 80% of its initial capacity. A four-fold increase in life cycle when the SoC is above 50% compared to 0% (Guena and Leblanc 2006). By limiting the maximum

and minimum threshold the ESS is discharged, can increase the life cycle at the expense of not fully utilizing it.

The rating of ESS is expressed in (kWh), therefore SoC of ESS can be expressed as

$$SoC_{ess(n)} = \frac{E_{ess(n)}}{E_{ess(max)}} \times 100\% \quad (2.4)$$

Where $E_{ess(n)}$ is the present capacity of the ESS and $E_{ess(max)}$ is maximum capacity of the ESS.

The shortfall in the modelled energy management system is that there is no room for intelligent load shedding, to give room to supply the critical loads within the microgrid when the MG runs short of energy. In a case when the $P_{balance}$ demanded so much from the ESS and its state of charge fell below the acceptable range the entire MG will shut down.

Zaidi, Zia, and Kupzog (2010) implemented a load recognition energy management system that is able to recognize non-critical loads and disconnects them in times of energy short falls within the microgrid. The resulting EMS was managed by a microgrid central controller, and one of its dedicated duties was to disconnect non-critical loads if need be. The shortfall of this EMS is that its energy management is centered on load shedding only, which is not enough to properly manage the energy within the microgrid. There was also need to harness all the other energy inputs sources to the microgrid.

2.3.2 Research Gaps and Deductions from Reviewed Micro Grid EMS

The following deductions were made after the review of several works on existing models of Energy Managements System (EMS) in microgrids:

- (a) Over complexity of energy management system (EMS) due to the introduction of multiple control and switching points make the EMS susceptible to possible failure; hence there is need for a smarter and less complex EMS to reduce the possibility of failure.
- (b) Miniature prototype of the envisaged EMS will not definitely represent the real life EMS and several real time aspect of the envisaged EMS cannot be accurately tested. Modelling and simulation would be a better approach since

the real life conditions of the modelled system can be characterized and simulated to get the actual system response.

- (c) The use of multiple agents in EMS could make the entire system susceptible to catastrophic failure, as there is a possibility of failure of any of the agents. Also it will make troubleshooting tedious and result to unnecessary system downtime in the case of any failure. A single agent, LIA with multiple functions will alleviate the unnecessary complication that will be posed by managing many agents.
- (d) The reliability of the EMS on the utility grid to increase the BESS State of Charge (SoC) is only applicable in areas with stable and reliable supply from the utility grid; the microgrid will fail if deployed in areas with unreliable and unstable utility grid supply as in our case study. The primary source of power in a microgrid should be the renewable sources.

CHAPTER THREE

METHODOLOGY

3.1 Architecture of the Smart Campus Hybrid Microgrid (SCHMG) Test-bed.

Modelling and Quantitative analysis methods were adopted for this research.

The SCHMG at Nnamdi Azikiwe University Awka consist of four (4) sub-grids. A block Illustrations of one of the sub-grids is as shown in figures 3.1. Each sub-grid has its own diesel generator, solar plant, Auxiliary power input (AUX), point of common coupling (PCC) to the utility grid and local intelligent agent (LIA) for intelligent energy management and electrical loads, categorized into high priority loads(hpls), priority loads(pls) and less priority loads(lpls). The input arrows to the LIA from the different energy sources to the sub-grids are two headed because the LIA receives information of their status from them and also sends control switching signals when they need to engage or disengage from the bus, depending on LIA decisions. Appendix D shows the schematic of the entire SCHMG.

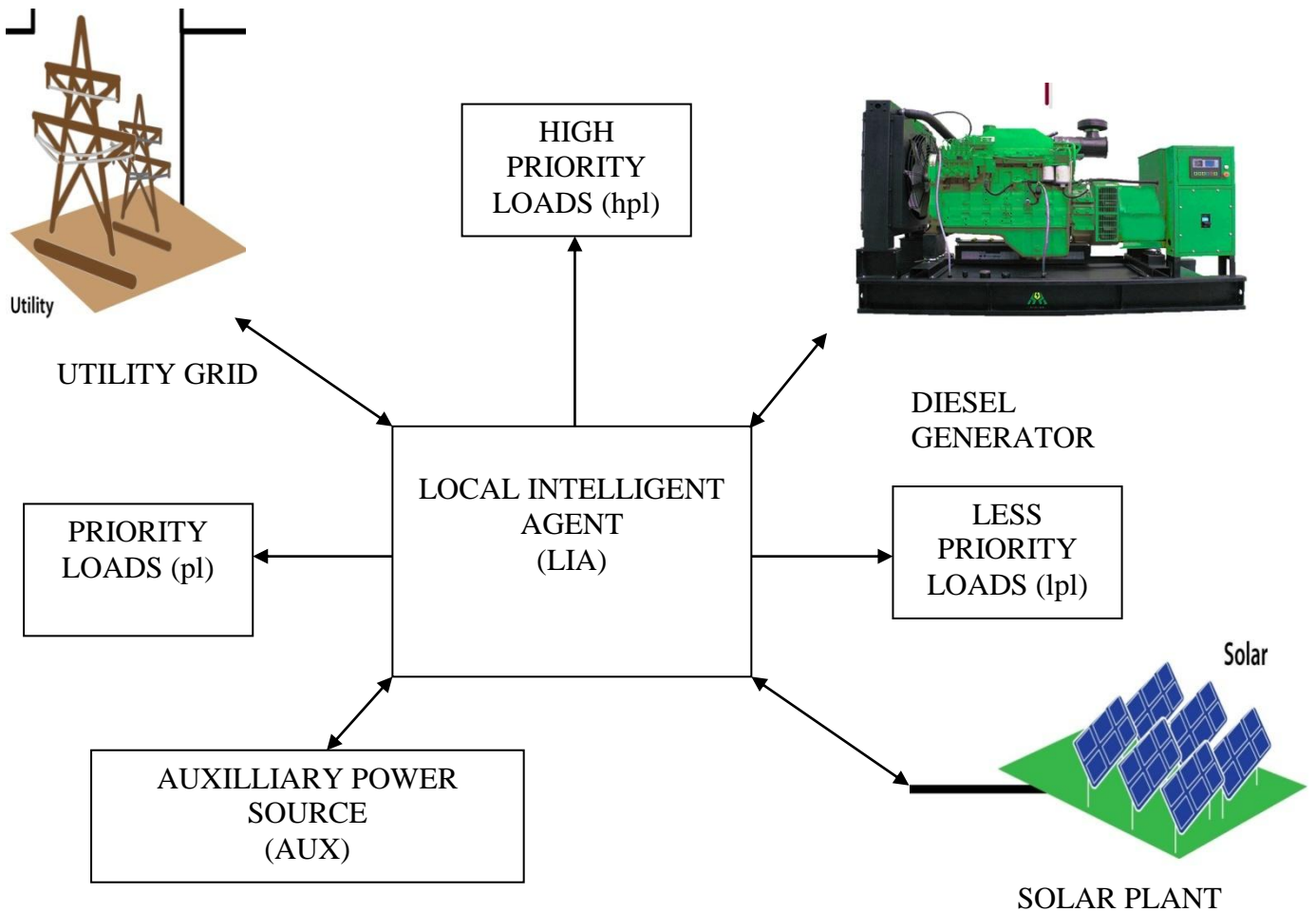

Figure 3.1: The block Representation of the Sub-grids

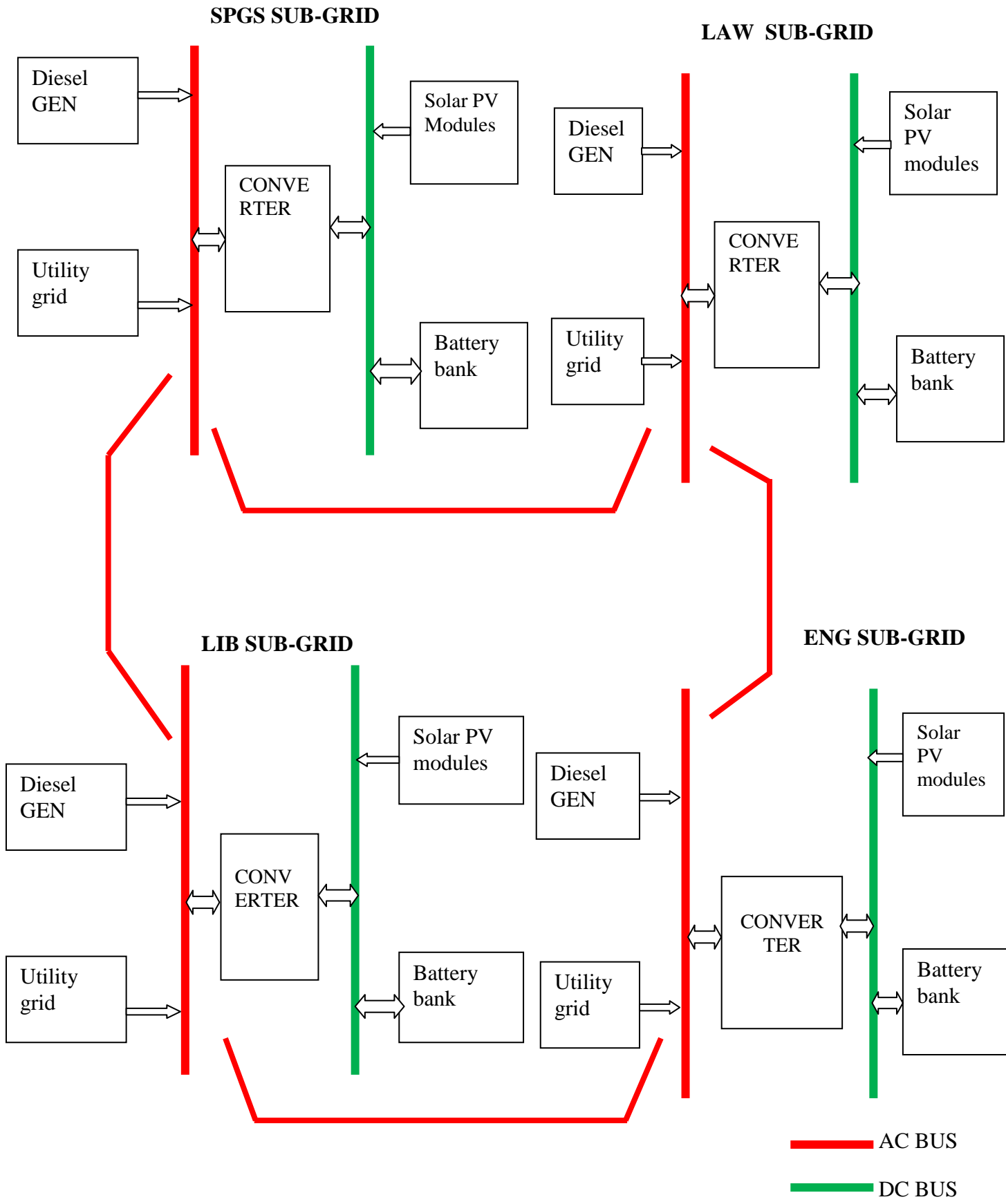

Figure 3.4: The block diagram of the Smart Campus Hybrid Microgrid

3.2 Experimental Measurement and Data Collection on the MG Sub-grids

To ensure that a very reliable and cost effective model was developed, certain careful steps were taken to gather all the requirements for the development. First, there was a careful electrical load estimation of existing installed electrical loads at the different Sub-grids. Then a mathematical model was developed for the sub-grids, which was applied for load analysis. Also, the loads at the sub-grids were categorised into high priority (hpl), priority (pl) and less priority loads (lpl). The control within each of sub-grids is managed by a Local Intelligent Agent (LIA). These intelligent agents are in-charge of Energy management within various sub-grids. In addition, each sub-grid can run in an island mode or share excess generated energy with a neighbouring sub-grid. The exchange of energy from one sub-grid to the other is dependent on the status of each sub-grid that is, whether it has excess or needs extra.

3.2.1 Electrical Load Estimation at the Four (4) Sub-grids

Electrical load estimation was carried out at the four sub-grids located at School of Post graduate Studies (SPGS), Faculty of Law (LAW), University Library (LIB) and the Faculty of Engineering (ENG) all at Nnamdi Azikiwe University (NAU) Awka Campus in order to properly size the solar-PV, Battery Energy Storage System (BESS) and the other components required to setup each of the sub-grids. Each sub-grid is designed to operate with a high degree of autonomy, except when it is giving or receiving energy to or from a neighbouring sub-grid via its Auxiliary Power input (AUX). The LIAs are deployed to control the activities of each of these sub-grids. After the load estimation, the load profiles for the sub-grids were designed using the Hybrid Optimization Model for Electric Renewables (HOMER) software.

The electrical loads estimated are presented in Tables 3.1 to 3.4. The tables are made up of six columns namely; Serial Number (S/N), Load description, Quantity (Qty), Power (W), Operating time (Hrs) and Energy in (WH). The Load description describes the electrical load being estimated, the Qty column gives the quantity of the loads, Power (W) refers to the power of the electrical loads as indicated on its name plate, Time in Hours refers to the operating time of the electrical load being estimated while the Energy in kWh is given by the power (kW) multiplied by the operating time.

3.2.1.1 Electrical Load Estimation at the SPGS Sub-grid

The electrical load estimation conducted at the SPGS is as shown in Table 3.1. The ratings of the electrical loads are obtained from their name plates respectively.

Table 3.1 Electrical Load Estimation for the SPGS NAU Sub-grid

S/N	Load Description	Qty	Power in (W)	Operating Time (Hrs)	Energy (kWH)
1	Ceiling Fans (60W)	36	2160	9	19.440
2	Industrial Fans (150W)	8	1200	9	10.800
3	Split Unit ac (1250W)	34	42500	9	382.500
4	Photocopiers (1200W)	3	3600	4	14.400
5	Photocopiers (1450W)	4	5800	4	23.200
6	Printers (150W)	18	2700	4	10.800
7	Desktop Computers (150W)	24	3600	8	28.800
8	Table Top Refrigerators (105W)	17	1785	8	14.280
9	Water Dispensers (600W)	15	9000	7	63.000
10	Lighting Points (60W)	115	6900	9	62.100
11	32inches LED TV (60W)	3	180	7	1.260
12	40inch LED TV (100W)	1	100	7	0.700
13	60inch LED TV (150W)	1	150	4	0.600
14	50W LED Flood Lamp (Security lighting)	6	300	12	3.600
15	15A outlet Car Charging Ports (new input)	2	4800	9	43.200
16	Public Address System (1000W)	1	1000	5	5.000
17	Giant Standing a.c (2600W)	2	5200	5	26.000
18	50W LED indoor light	19	950	5	4.750
19	Water pumps (0.75kW)	2	1500	4	6.000
Total			93425 W		720.430kWH

3.2.1.2 Electrical Load Estimation at the LAW Sub-grid

The electrical load estimation conducted at the Faculty of Law (LAW) NAU Awka Campus is as shown in Table 3.2.

Table 3.2 Electrical Load Estimation for Law Faculty NAU Awka Campus

S/N	Load Description	Qty	Rated Power (Watts)	Operating Time (Hrs)	Energy (kWH)
1	Ceiling Fans (60W)	165	9900	9	89.100
2	Industrial Fans (150W)	8	22500	9	202.500
3	Split Unit ac (2000W)	76	152000	9	1368.000
4	Split Unit ac (1400W)	41	54700	9	492.300
5	3 Phase central ac units(11500W)	3	34500	9	310.500
6	Giant a.c Units(5000W)	5	25000	9	225.000
7	Photocopiers (1200W)	2	2400	4	9.600
8	Photocopiers (1450W)	4	5800	4	23.200
9	Printers (150W)	10	1500	4	6.000
10	Desktop Computers (150W)	24	3600	8	28.800
11	Refrigerators (105W)	28	2940	8	23.520
12	Water Dispensers (600W)	25	15000	7	105.000
13	Lighting Points (40W)	400	16000	9	144.000
14	32inches LED TV (60W)	5	300	7	2.100
15	40inch LED TV (100W)	2	200	7	1.400
16	60inch LED TV (150W)	2	300	4	1.200
17	50W LED Flood Lamp (Security lighting)	7	350	13	4.550
18	I5A outlet Car Charging Ports (new input)	3	7200	9	64.800
19	Lecture hall Public Address System(1000W)	1	1000	5	5.000
20	50W LED indoor light	19	950	5	4.750
21	Water pumps(1500W)	3	4500	4	18.000
Total			360640 W	3129.32kWh	

3.2.1.3 Electrical Load Estimation at LIB Sub-grid

In the same manner, the electrical load estimation conducted at the University library NAU Awka Campus is as shown in Table 3.3.

Table 3.3 Electrical Load Estimation for University Library NAU Awka Campus

S/N	Load Description	QTY	Power (Watts)	Time (Hrs)	Energy (kWH)
1	Ceiling Fans (60W)	200	12000	9	108.000
2	Industrial Fans (150W)	10	1500	9	13.500
3	Split Unit ac (2000W)	41	82000	9	738.000
4	Giant Standing ac (5580W)	27	150660	9	1355.940
5	Giant Standing ac (8300W)	8	66400	9	597.600
6	Split Unit ac (1125W)	10	11250	9	101.250
7	Split Unit ac (1350W)	10	13500	9	121.500
8	Photocopiers (1200W)	7	8400	4	33.600
9	Photocopiers (1450W)	9	13050	4	53265.3
10	Printers (150W)	30	4500	4	18367.3
11	Desktop Computers (150W)	1520	228000	8	1861224.5
12	Refrigerators (500W)	2	1000	6	6666.7
13	Refrigerators (300W)	1	300	8	2666.7
14	Deep freezer (500W)	2	1000	6	6666.7
15	4in One fluorescent lamp(120W)	881	105,720	9	1057200.003
16	Water Dispensers (600W)	10	6000	7	44210.5
17	Lighting Points (40W)	608	24320	9	223346.9
18	32inches LED TV (60W)	10	600	7	4285.7
19	40inch LED TV (100W)	1	100	7	714.3
20	60inch LED TV (150W)	1	150	4	612.2
21	50W LED Flood Lamp (Security lighting)	20	1000	13	13265.3
22	I5A outlet Car Charging Ports(new input) (2405W output)	4	9620	9	90947.4
23	50W LED indoor light	25	1250	5hrs	6578.9
24	Water pumps(1500)	3	4500	4hrs	20000.0
	TOTAL		746,820.0 W		5,491,485.703 VAH

3.2.1.4 Electrical Load Estimation at the Faculty of Engineering Sub-grid

Finally, Table 3.4 presents the electrical load estimation conducted at the Faculty of Engineering NAU Awka Campus.

Table 3.4 Electrical Load Estimation for Faculty of Engineering NAU Awka Campus

S/N	Load Description	Qty	Power in Watts	Operating Time in Hrs	Energy (kWH)
1	Ceiling Fans (60W)	91	5460	9	55213.5
2	Industrial Fans (150W)	10	1500	9	15000.0
3	Split Unit ac (2000W)	75	150000	9	1500000.0
4	Photocopiers (1200W)	10	12000	4	48979.6
5	Photocopiers (1450W)	5	7250	4	29591.8
6	Printers (150W)	10	1500	4	6122.4
7	Desktop Computers (150W)	30	4500	8	36734.7
8	Refrigerators (150W)	15	2250	6	15000.0
9	Water Dispensers (600W)	10	6000	7	44210.5
10	Lighting Points (40W)	278	24320	9	102122.4
11	32inches LED TV (60W)	10	600	7	4285.7
12	50W LED Flood Lamp (Security lighting)	20	1000	13	13265.3
13	15A outlet Car Charging Ports(new input) (2400W output)	4	9600	9	90947.4
14	Water pumps(1500)	2	3000	4	13333.3
15	Engineering Laboratory / workshops		260890	7	18262860
	TOTAL		228980.0W		20237666.6

3.2.2 Summary of Electrical Load Estimation of at the Sub-grids

The electrical load estimation is the physical assessment of the existing electrical loads in kW, currently installed in each sub-grid. The summary of the electrical load estimation at the various sub-grids are presented in Table 3.5.

Table 3.5 The Summary of Electrical Load estimation at the various Sub-grids

Load Types In Kw	Chosen Sites For The Campus Hybrid Solar-Diesel Micro-Grid			
	The S.P.G School	Law Faculty	University Library	Engineering Faculty
Lighting	5.17	16	90.2	11.52
Water Pumping	1.5	4.5	4.5	3
Fans	2.8	9.9	22.17	7.86
Refrigerators /water dispensers	9.48	13.8	10.5	10.57
Air conditioning	42.7	268.9	400.3	150
Photocopiers Computers and Printers	15.5	25.6	189.15	15.8
Security lighting / Gadgets	5.5	8	20	8.5
Other Loads	10.775	13.94	10	21.73
Engineering Laboratories/Workshops				260.890
Total	93.425	360.640	746.82	489.870
Grand Total of the Loads for the four sites in kW	1,690.755kW \approx 1.690755MW			

3.3 Electrical Load Profile using HOMER

The results of the Load estimation at the various sub-grids were used to generate a 60-minutes step, 24-hour load profile in HOMER software for one year. HOMER grid software simulation tool gives room for the selection of the best suitable load profile category for any type of MG design. The available options are, the residential, Industrial, commercial and community load profile categories. The best suited load profile category is the commercial category. After the choice of load profile category, HOMER grid gives sample 60-minutes, 24-hour load profile which can be used for analysis. The software also gives the room for the modification of the provided sample load profile to suit a custom load profile as in the case of SCHMG in NAU. Table 3.6 shows the modification of the daily load profile for week-days and week-ends. The different categories of load profile are as shown in figure 3.5, while figure 3.6 shows the selected load profile category. The load profiles for the various sub-grids generated by HOMER GRID are presented in Tables 3.7 to 3.10.

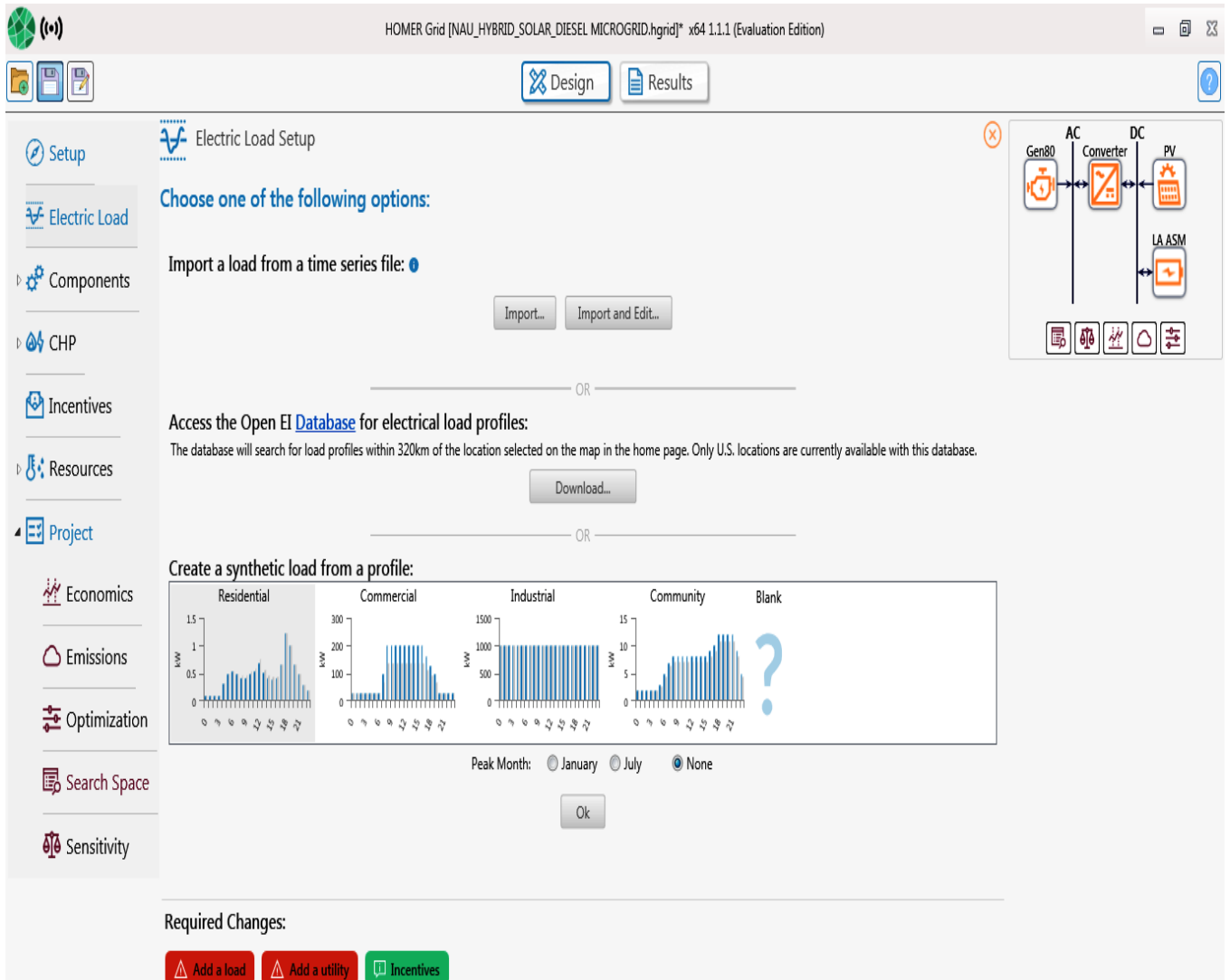

Figure 3.6: The Load profile categories provided in HOMER grid.

From the Load profile categories provided, the best suited for the four Sub-grids is the commercial load profile category. This is because the sub-grids start their full day activities at 8am and ends at 4pm. Figure 3.7 graphically shows the commercial load profile category for 200kW load.

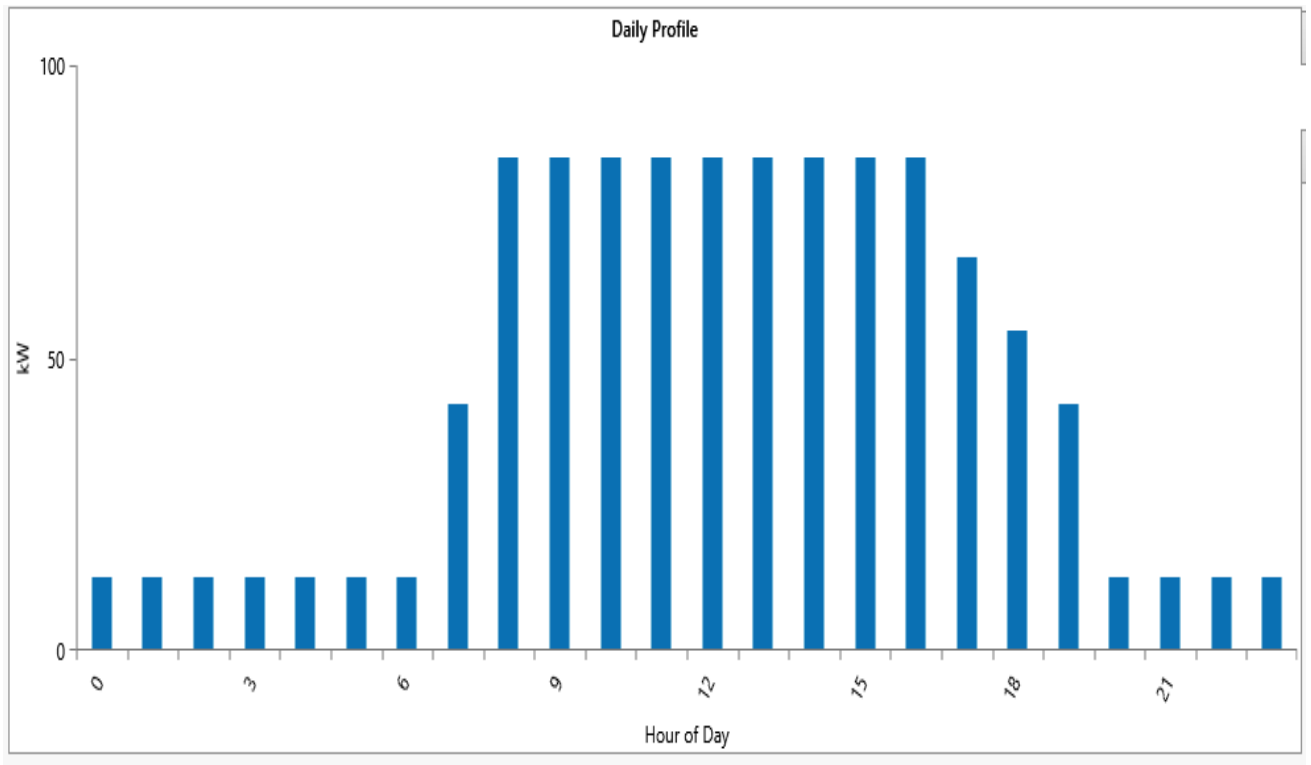

Figure 3.7: The Commercial Daily Profile Category.

Table 3.6: HOMER 60 minutes step 24-hour Load Profile for Commercial Load profile category

Hours	Week- Days Load Profile(kW)	Week -end Load Profile(kW)
0	(15% x200)= 30.00	(15% x200)= 30.00
1	(15% x200)= 30.00	(15% x200)= 30.00
2	(15% x200)= 30.00	(15% x200)= 30.00
3	(15% x200)= 30.00	(15% x200)= 30.00
4	(15% x200)= 30.00	(15% x200)= 30.00
5	(15% x200)= 30.00	(15% x200)= 30.00
6	(15% x200)= 30.00	(15% x200)= 30.00
7	(50% x200)= 100.00	(70% x 50% x200)= 70.00
8	(100% x 200)=200.00	(70% x 100% x 200)=140.00
9	(100% x 200)=200.00	(70% x 100% x 200)=140.00
10	(100% x 200)=200.00	(70% x 100% x 200)=140.00
11	(100% x 200)=200.00	(70% x 100% x 200)=140.00
12	(100% x 200)=200.00	(70% x 100% x 200)=140.00
13	(100% x 200)=200.00	(70% x 100% x 200)=140.00
14	(100% x 200)=200.00	(70% x 100% x 200)=140.00

15	(100% x 200)=200.00	(70% x 100% x 200)=140.00
16	(100% x 200)=200.00	(70% x 100% x 200)=140.00
17	(80% x 200)= 160.00	(70% x 80% x 200)=112.00
18	(65% x 200)= 130.00	(70% x 65% x 200)=91.00
19	(50% x200)= 100.00	(70% x 50% x200)= 70.00
20	(15% x200)= 30.00	(15% x200)= 30.00
21	(15% x200)= 30.00	(15% x200)= 30.00
22	(15% x200)= 30.00	(15% x200)= 30.00
23	(15% x200)= 30.00	(15% x200)= 30.00

Table 3.7: One year Load Profile for the SPGS Sub-grid for week-days in kW

Hrs	Jan.	Feb.	March	April	May	June	July	Aug.	Sept.	Oct.	Nov.	Dec.
0	12.623	12.623	12.623	12.623	12.623	12.623	12.623	12.623	12.623	12.623	12.623	12.623
1	12.623	12.623	12.623	12.623	12.623	12.623	12.623	12.623	12.623	12.623	12.623	12.623
2	12.623	12.623	12.623	12.623	12.623	12.623	12.623	12.623	12.623	12.623	12.623	12.623
3	12.623	12.623	12.623	12.623	12.623	12.623	12.623	12.623	12.623	12.623	12.623	12.623
4	12.623	12.623	12.623	12.623	12.623	12.623	12.623	12.623	12.623	12.623	12.623	12.623
5	12.623	12.623	12.623	12.623	12.623	12.623	12.623	12.623	12.623	12.623	12.623	12.623
6	12.623	12.623	12.623	12.623	12.623	12.623	12.623	12.623	12.623	12.623	12.623	12.623
7	42.075	42.075	42.075	42.075	42.075	42.075	42.075	42.075	42.075	42.075	42.075	42.075
8	84.15	84.15	84.15	84.15	84.15	84.15	84.15	84.15	84.15	84.15	84.15	84.15
9	84.15	84.15	84.15	84.15	84.15	84.15	84.15	84.15	84.15	84.15	84.15	84.15
10	84.15	84.15	84.15	84.15	84.15	84.15	84.15	84.15	84.15	84.15	84.15	84.15
11	84.15	84.15	84.15	84.15	84.15	84.15	84.15	84.15	84.15	84.15	84.15	84.15
12	84.15	84.15	84.15	84.15	84.15	84.15	84.15	84.15	84.15	84.15	84.15	84.15
13	84.15	84.15	84.15	84.15	84.15	84.15	84.15	84.15	84.15	84.15	84.15	84.15
14	84.15	84.15	84.15	84.15	84.15	84.15	84.15	84.15	84.15	84.15	84.15	84.15
15	84.15	84.15	84.15	84.15	84.15	84.15	84.15	84.15	84.15	84.15	84.15	84.15
16	84.15	84.15	84.15	84.15	84.15	84.15	84.15	84.15	84.15	84.15	84.15	84.15
17	67.32	67.32	67.32	67.32	67.32	67.32	67.32	67.32	67.32	67.32	67.32	67.32
18	54.7	54.7	54.7	54.7	54.7	54.7	54.7	54.7	54.7	54.7	54.7	54.7
19	42.075	42.075	42.075	42.075	42.075	42.075	42.075	42.075	42.075	42.075	42.075	42.075
20	12.623	12.623	12.623	12.623	12.623	12.623	12.623	12.623	12.623	12.623	12.623	12.623
21	12.623	12.623	12.623	12.623	12.623	12.623	12.623	12.623	12.623	12.623	12.623	12.623
22	12.623	12.623	12.623	12.623	12.623	12.623	12.623	12.623	12.623	12.623	12.623	12.623
23	12.623	12.623	12.623	12.623	12.623	12.623	12.623	12.623	12.623	12.623	12.623	12.623

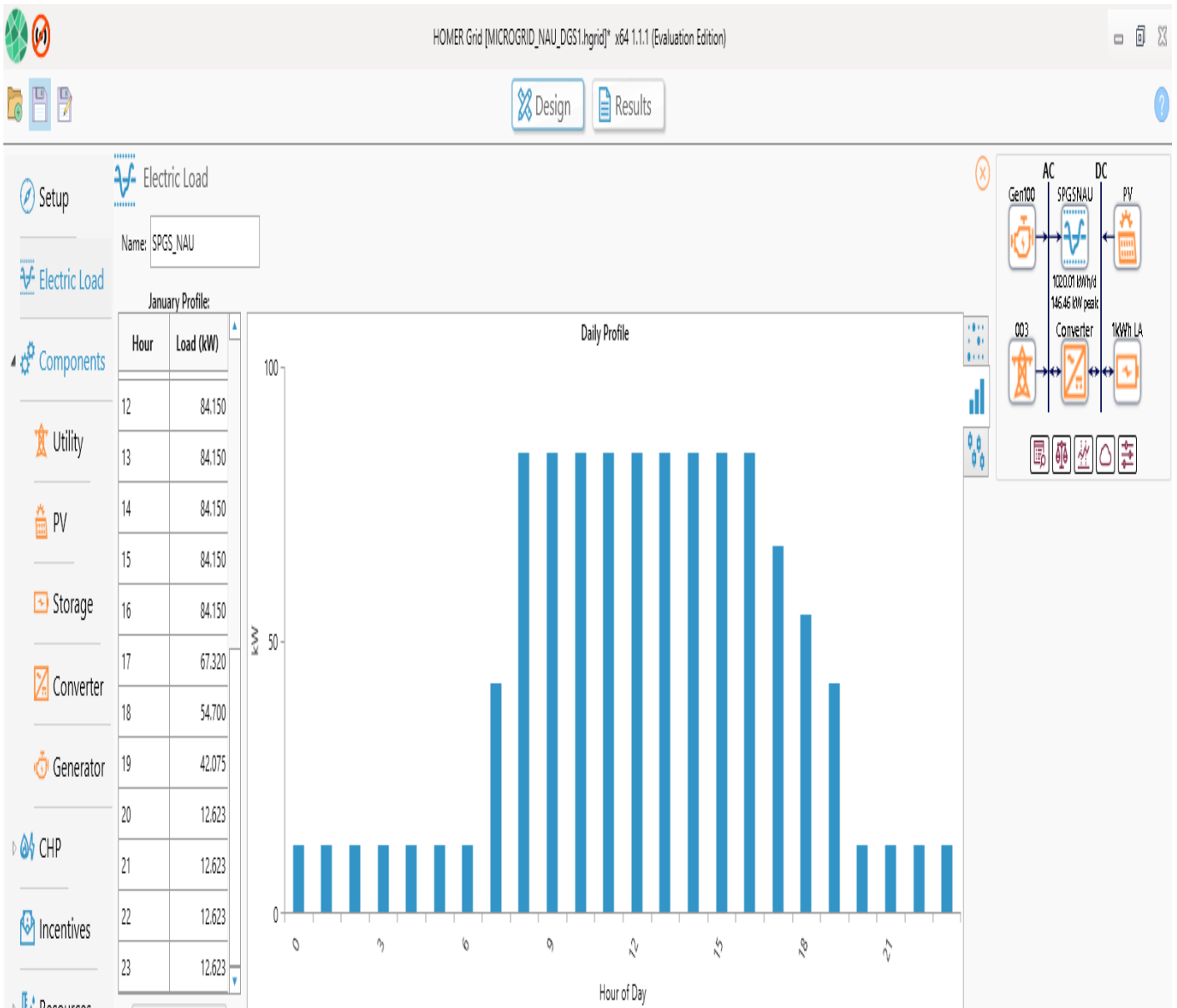

Figure 3.8 Daily Load profile for the SPGS Sub-grid

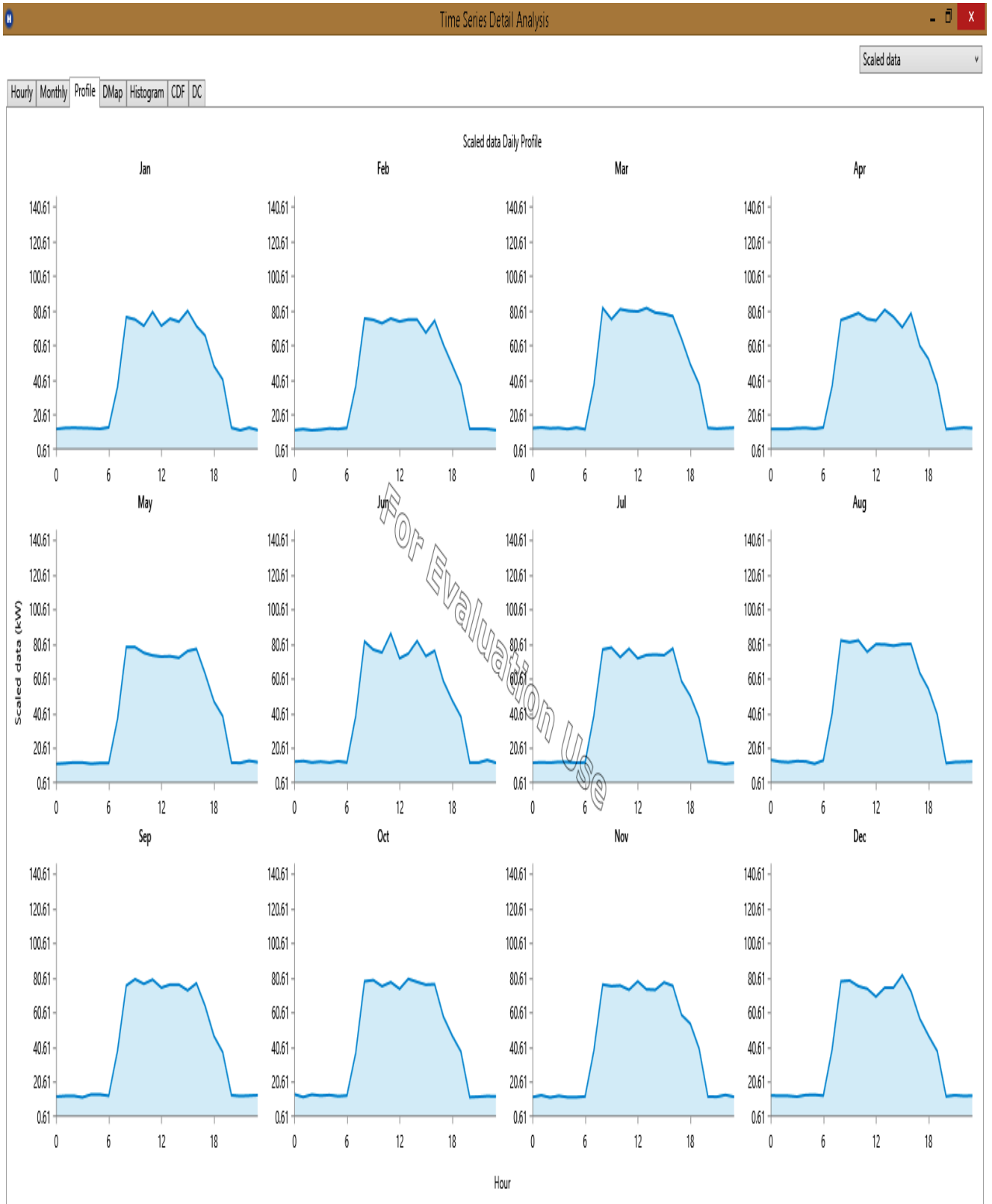

Figure 3.9: Monthly Load profile for SPGS Sub-grids

Table 3.8: One year Load Profile for LAW Sub-grid for week-days in kW

Hrs	Jan.	Feb.	March	April	May	June	July	Aug.	Sept.	Oct.	Nov.	Dec.
0	52.755	52.755	52.755	52.755	52.755	52.755	52.755	52.755	52.755	52.755	52.755	52.755
1	52.755	52.755	52.755	52.755	52.755	52.755	52.755	52.755	52.755	52.755	52.755	52.755
2	52.755	52.755	52.755	52.755	52.755	52.755	52.755	52.755	52.755	52.755	52.755	52.755
3	52.755	52.755	52.755	52.755	52.755	52.755	52.755	52.755	52.755	52.755	52.755	52.755
4	52.755	52.755	52.755	52.755	52.755	52.755	52.755	52.755	52.755	52.755	52.755	52.755
5	52.755	52.755	52.755	52.755	52.755	52.755	52.755	52.755	52.755	52.755	52.755	52.755
6	52.755	52.755	52.755	52.755	52.755	52.755	52.755	52.755	52.755	52.755	52.755	52.755
7	175.85	175.85	175.85	175.85	175.85	175.85	175.85	175.85	175.85	175.85	175.85	175.85
8	351.7	351.7	351.7	351.7	351.7	351.7	351.7	351.7	351.7	351.7	351.7	351.7
9	351.7	351.7	351.7	351.7	351.7	351.7	351.7	351.7	351.7	351.7	351.7	351.7
10	351.7	351.7	351.7	351.7	351.7	351.7	351.7	351.7	351.7	351.7	351.7	351.7
11	351.7	351.7	351.7	351.7	351.7	351.7	351.7	351.7	351.7	351.7	351.7	351.7
12	351.7	351.7	351.7	351.7	351.7	351.7	351.7	351.7	351.7	351.7	351.7	351.7
13	351.7	351.7	351.7	351.7	351.7	351.7	351.7	351.7	351.7	351.7	351.7	351.7
14	351.7	351.7	351.7	351.7	351.7	351.7	351.7	351.7	351.7	351.7	351.7	351.7
15	351.7	351.7	351.7	351.7	351.7	351.7	351.7	351.7	351.7	351.7	351.7	351.7
16	351.7	351.7	351.7	351.7	351.7	351.7	351.7	351.7	351.7	351.7	351.7	351.7
17	281.36	281.36	281.36	281.36	281.36	281.36	281.36	281.36	281.36	281.36	281.36	281.36
18	228.605	228.605	228.605	228.605	228.605	228.605	228.605	228.605	228.605	228.605	228.605	228.605
19	175.85	175.85	175.85	175.85	175.85	175.85	175.85	175.85	175.85	175.85	175.85	175.85
20	52.755	52.755	52.755	52.755	52.755	52.755	52.755	52.755	52.755	52.755	52.755	52.755
21	52.755	52.755	52.755	52.755	52.755	52.755	52.755	52.755	52.755	52.755	52.755	52.755
22	52.755	52.755	52.755	52.755	52.755	52.755	52.755	52.755	52.755	52.755	52.755	52.755
23	52.755	52.755	52.755	52.755	52.755	52.755	52.755	52.755	52.755	52.755	52.755	52.755

Table 3.9: One year Load Profile for LIB Sub-grid for week-days in kW

Hrs	Jan.	Feb.	March	April	May	June	July	Aug.	Sept.	Oct.	Nov.	Dec.
0	112.023	112.023	112.023	112.023	112.023	112.023	112.023	112.02	112.023	112.023	112.023	112.023
1	112.023	112.023	112.023	112.023	112.023	112.023	112.023	112.02	112.023	112.023	112.023	112.023
2	112.023	112.023	112.023	112.023	112.023	112.023	112.023	112.02	112.023	112.023	112.023	112.023
3	112.023	112.023	112.023	112.023	112.023	112.023	112.023	112.02	112.023	112.023	112.023	112.023
4	112.023	112.023	112.023	112.023	112.023	112.023	112.023	112.02	112.023	112.023	112.023	112.023
5	112.023	112.023	112.023	112.023	112.023	112.023	112.023	112.02	112.023	112.023	112.023	112.023
6	112.023	112.023	112.023	112.023	112.023	112.023	112.023	112.02	112.023	112.023	112.023	112.023
7	373.41	373.41	373.41	373.41	373.41	373.41	373.41	373.41	373.41	373.41	373.41	373.41
8	746.82	746.82	746.82	746.82	746.82	746.82	746.82	746.82	746.82	746.82	746.82	746.82
9	746.82	746.82	746.82	746.82	746.82	746.82	746.82	746.82	746.82	746.82	746.82	746.82
10	746.82	746.82	746.82	746.82	746.82	746.82	746.82	746.82	746.82	746.82	746.82	746.82
11	746.82	746.82	746.82	746.82	746.82	746.82	746.82	746.82	746.82	746.82	746.82	746.82
12	746.82	746.82	746.82	746.82	746.82	746.82	746.82	746.82	746.82	746.82	746.82	746.82

13	746.82	746.82	746.82	746.82	746.82	746.82	746.82	746.82	746.82	746.82	746.82	746.82
14	746.82	746.82	746.82	746.82	746.82	746.82	746.82	746.82	746.82	746.82	746.82	746.82
15	746.82	746.82	746.82	746.82	746.82	746.82	746.82	746.82	746.82	746.82	746.82	746.82
16	746.82	746.82	746.82	746.82	746.82	746.82	746.82	746.82	746.82	746.82	746.82	746.82
17	597.456	597.456	597.456	597.456	597.456	597.456	597.456	597.46	597.456	597.456	597.456	597.456
18	485.443	485.443	485.443	485.443	485.443	485.443	485.443	485.44	485.443	485.443	485.443	485.443
19	373.41	373.41	373.41	373.41	373.41	373.41	373.41	373.41	373.41	373.41	373.41	373.41
20	112.023	112.023	112.023	112.023	112.023	112.023	112.023	112.02	112.023	112.023	112.023	112.023
21	112.023	112.023	112.023	112.023	112.023	112.023	112.023	112.02	112.023	112.023	112.023	112.023
22	112.023	112.023	112.023	112.023	112.023	112.023	112.023	112.02	112.023	112.023	112.023	112.023
23	12.623	12.623	12.623	12.623	12.623	12.623	12.623	12.623	12.623	12.623	12.623	12.623

Table 3.10: One year Load Profile for ENG Sub-grid for week-days in kW

Hrs	Jan.	Feb.	March	April	May	June	July	Aug.	Sept.	Oct.	Nov.	Dec.
0	31.511	31.511	31.511	31.511	31.511	31.511	31.511	31.511	31.511	31.511	31.511	31.511
1	31.511	31.511	31.511	31.511	31.511	31.511	31.511	31.511	31.511	31.511	31.511	31.511
2	31.511	31.511	31.511	31.511	31.511	31.511	31.511	31.511	31.511	31.511	31.511	31.511
3	31.511	31.511	31.511	31.511	31.511	31.511	31.511	31.511	31.511	31.511	31.511	31.511
4	31.511	31.511	31.511	31.511	31.511	31.511	31.511	31.511	31.511	31.511	31.511	31.511
5	31.511	31.511	31.511	31.511	31.511	31.511	31.511	31.511	31.511	31.511	31.511	31.511
6	31.511	31.511	31.511	31.511	31.511	31.511	31.511	31.511	31.511	31.511	31.511	31.511
7	105.035	105.035	105.035	105.035	105.035	105.035	105.035	105.035	105.035	105.035	105.035	105.035
8	210.07	210.07	210.07	210.07	210.07	210.07	210.07	210.07	210.07	210.07	210.07	210.07
9	210.07	210.07	210.07	210.07	210.07	210.07	210.07	210.07	210.07	210.07	210.07	210.07
10	210.07	210.07	210.07	210.07	210.07	210.07	210.07	210.07	210.07	210.07	210.07	210.07
11	210.07	210.07	210.07	210.07	210.07	210.07	210.07	210.07	210.07	210.07	210.07	210.07
12	210.07	210.07	210.07	210.07	210.07	210.07	210.07	210.07	210.07	210.07	210.07	210.07
13	210.07	210.07	210.07	210.07	210.07	210.07	210.07	210.07	210.07	210.07	210.07	210.07
14	210.07	210.07	210.07	210.07	210.07	210.07	210.07	210.07	210.07	210.07	210.07	210.07
15	210.07	210.07	210.07	210.07	210.07	210.07	210.07	210.07	210.07	210.07	210.07	210.07
16	210.07	210.07	210.07	210.07	210.07	210.07	210.07	210.07	210.07	210.07	210.07	210.07
17	168.056	168.056	168.056	168.056	168.056	168.056	168.056	168.056	168.056	168.056	168.056	168.056
18	136.546	136.546	136.546	136.546	136.546	136.546	136.546	136.546	136.546	136.546	136.546	136.546
19	105.035	105.035	105.035	105.035	105.035	105.035	105.035	105.035	105.035	105.035	105.035	105.035
20	31.511	31.511	31.511	31.511	31.511	31.511	31.511	31.511	31.511	31.511	31.511	31.511
21	31.511	31.511	31.511	31.511	31.511	31.511	31.511	31.511	31.511	31.511	31.511	31.511
22	31.511	31.511	31.511	31.511	31.511	31.511	31.511	31.511	31.511	31.511	31.511	31.511
23	31.511	31.511	31.511	31.511	31.511	31.511	31.511	31.511	31.511	31.511	31.511	31.511

3.4 Cost Analysis of Electric Supply to the Sub-grids by the Conventional methods of Diesel Generator and Utility Grid

3.4.1 Utility Grid Availability at Nnamdi Azikiwe University Awka

From study on the installed electrical loads at Nnamdi Azikiwe University Awka Campus, the electrical loads at NAU Awka being supplied from the utility grid was estimated to be approximately 5,385 kW = 5.385MW

Table 3.11 shows the electric energy consumption by the Campus as recorded by the EEDC energy meter for the year 2018.

Table 3.11: Energy Supply from EEDC in 2018

Month	Billing Rate (NGN)	Consumption (kWh)	Date paid	Amount (NGN)
January 2018	45.26	182,770	5/01/18	8,685,778.71
February 2018	45.26	53,670	14/02/18	2,550,559.41
March 2018	45.26	96,200	14/03/18	4,571,712.60
April 2018	45.26	291,840	10/04/18	13,869,112.32
May 2018	45.26	226,980	7/05/18	10,786,770.54
June 2018	45.26	184,800	7/06/18	8,782,250.40
July 2018	45.26	269,916	3/07/18	12,827,218.07
August 2018	45.26	249,457	6/08/18	11,854,945.01
Sept. 2018	45.26	180,497	7/09/18	8,577,758.93
October 2018	45.26	175,640	2/10/18	8,346,939.72
November 2018	45.26	182,530	5/11/18	8,674,373.19
December 2018	45.26	165,020,	4/12/18	7,842,245.46
TOTAL		2,259,320		107,369,664.36

Let Utility Grid Availability be denoted by UG_{av}

UG_{av} is defined as the number hours quality electric energy is supplied by the utility grid (that is EEDC), to NAU Awka Campus. Quality here implies useful electric energy.

Assuming UG_{av} is the same for the whole campus, since the source is the same.

Taking the month of April as a case study, the approximate number of Hours electricity was supplied from the utility grid can be estimated from (3.1).

$$\text{Hours of Electricity Supply} = \frac{\text{Consumption in kWh for April(2018)}}{\text{Electrical Loads(kWh)}} \quad (3.1)$$

From Table 3.11,

$$\text{Hours of Electricity Supply for April(2018)} = \frac{291,840\text{kWh}}{5,385\text{kW}} = 54.195\text{Hours}$$

This is the estimated time power was available from the utility grid.

But

Total number of hours Electricity is required in the day at the various Sub-grids = 9hours (8am to 5pm daily) =198 hours for one month

Assuming 22 working days in a month excluding weekends.

Also assuming electricity is required at night at the different sub-grids for an average of 31 days

Total number hours electricity is required at night = 12hrs (6pm to 7am)

The total number of hours electricity will be required in one month = 12 x31= 372 hours for one month.

Therefore the Total number of hours electricity is required at the Sub-grids for one month = 198 hours + 372 hours = 570 hours in one month

$$\text{Percentage } UG_{av} =$$

$$\frac{(\text{Hours of Electricity Supply for April(2018)})}{\text{Total Hours Electricity is required in a month}} \times 100\% \quad (3.2)$$

Where UG_{av} = Utility Grid Availability

From (3.2)

$$\text{Percentage } UG_{av} = (54.195 \div 570) \times 100\%$$

$$\text{Percentage } UG_{av} \text{ for the month of April 2018} = 9.508 \%$$

This Percentage UG_{av} is far less than what is needed; therefore electricity supply to the NAU Awka Campus cannot be based on only utility grid electricity supply.

However, electricity is most importantly needed at the four Sub-grids in the day time of the month for 198hours.

Assuming that the hours of grid availability is equally distributed between the day and the night times, then the number of hours the utility supplied energy to the sub-grids for the month of April 2018 will be 27.0975Hours.

While the number of hours without supply will be $198 - 27.0975 = 170.9025$ Hours.

This number of Hours has to be supplied by the diesel Generators at the various sub-grids.

From the HOMER grid software tool, the number of liters of diesel used by the diesel generators at the various sub-grids per hour was estimated, using the diesel fuel curve slope in (3.3).

$$\text{Fuel Curve Slope} = 0.253\text{L/hr/kW} \quad (3.3)$$

3.4.2 Estimated Cost of Running Diesel Generators at the different Sub-grids

(a) For the SPGS sub-grid,

Diesel Generator size = 100kVA

Power factor (PF) = 0.8

Diesel generator size in kW = $100\text{kVA} \times 0.8 = 80\text{kW}$

Therefore the number of litres of diesel required to run this generator for 170.9025 hours on full load capacity = $0.253\text{L/hr/kW} \times 170.9025 \text{ Hours} \times 80\text{kW} = 3459.067 \text{ Litres}$

The estimated cost of buying diesel for SPGS sub-grid for one month will be given by $3459.067 \times 250 = \text{N}864,766.00$

Annually the cost will be $\text{N}864,766.00 \times 12 = \text{N}10,377,201.00$

(b) For LAW Sub-grid,

Diesel Generator Size = 500kVA

Power factor (PF) = 0.8

Diesel generator size in kW = $500\text{kVA} \times 0.8 = 400\text{kW}$

Number litres of diesel required to run the generator for 170.9025Hours on full load capacity = $0.253\text{L/hr/kW} \times 170.9025 \times 400\text{kW} = 17295.333 \text{ Litres}$

The estimated cost for buying diesel for this Sub-grid for one month is given by $17295.333 \text{ Litres} \times 250 = \text{N}4,323,833.25$

Annually, the cost will be $\text{N}4,323,833.25 \times 12 = \text{N}51,885,999$

(c) For the LIB sub-grid,

Diesel Generator size = 1000kVA

Power factor (PF) = 0.8

Diesel generator size in kW = 100kVA x 0.8 = 80kW

Therefore the number of litres of diesel required to run this generator for 170.9025Hours =
 $0.253\text{L/hr/Kw} \times 170.9025\text{Hours} \times 80\text{kW} = 34590.666 \text{ Litres}$

The estimated cost of buying diesel for SPGS sub-grid for one month will be given by
 $34590.666 \text{ Litres} \times 250 = \text{N}8,647,666.50$

Annually the cost will be $\text{N}8,647,666.50 \times 12 = \text{N}103,771,998.00$

(d) For the ENG sub-grid,

Diesel Generator size = 370kVA

Power factor (PF) = 0.8

Diesel generator size in kW = 370kVA x 0.8 = 296kW

Therefore the number of litres of diesel required to run this generator for 170.9025Hours =
 $0.253\text{L/hr/Kw} \times 170.9025\text{Hours} \times 296\text{kW} = 12,798.54642 \text{ Litres}$

The estimated cost of buying diesel for SPGS sub-grid for one month will be given by
 $12,798.54642 \text{ Litres} \times 250 = \text{N}3,199,636.61$

Annually the cost will be $\text{N}3,199,636.61 \times 12 = \text{N}38,395,639.26$

In the same way the estimated cost of paying utility bills at the various sub-grids can be estimated as presented herein.

$$UG_{av} \times \text{estimated load of the subgrids} = \text{Estimated Consumption by the subgrid} \quad (3.4)$$

3.4.3 Estimated Cost of Paying Utility Bills at various Sub-grids

(a) For SPGS Sub-grid

Estimated electrical load = 93.425kW (see Table 3.5)

$UG_{av} = 54.195\text{hours}$

Therefore Estimated energy consumption by the Sub-grid is given by $93.425 \times 54.195 = 5063.168 \text{ kWh}$

Utility billing rate = N45.26 per kWh

The estimated cost of paying for electricity bills at SPGS sub-grid for one month = $45.26 \times 5063.168 = \text{N}229,158.98$

Annually the cost will be $\text{N}229,158.98 \times 12 = \text{N}2,749,907.76$

(b) For LAW Sub-grid

Estimated electrical load = 360.640kW (see Table 3.5)

$UG_{av} = 54.195$ hours

Therefore Estimated energy consumption by the Sub-grid is given by $360.640 \times 54.195 = 19544.885$ kWh

Utility billing rate = N45.26 per kWh

The estimated cost of paying for electricity bills at LAW sub-grid for one month = $45.26 \times 19544.885 = N884,601.50$

Annually the cost will be $N884,601.50 \times 12 = N10,615,218.00$

(c) For LIB Sub-grid

Estimated electrical load = 746.82kW (see Table 3.5)

$UG_{av} = 54.195$ hours

Therefore Estimated energy consumption by the Sub-grid is given by $746.82 \times 54.195 = 40473.91$ kWh

Utility billing rate = N45.26 per kWh

The estimated cost of paying for electricity bills at LIB sub-grid for one month = $45.26 \times 40473.91 = N1,831,849.17$

Annually the cost will be $N1,831,849.17 \times 12 = N21,982,189.99 \approx N21,982,190.00$

(d) For ENG Sub-grid

Estimated electrical load = 228.980kW (see Table 3.5)

$UG_{av} = 54.195$ hours

Therefore Estimated energy consumption by the Sub-grid is given by $228.980 \times 54.195 = 1,2409.571$ kWh

Utility billing rate = N45.26 per kWh

The estimated cost of paying for electricity bills at ENG sub-grid for one month = $45.26 \times 1,2409.571 = N561,657.19$

Annually the cost will be $N1,2409.571 \times 12 = 6,739,886.2558 \approx N6,739,886.26$

Table 3.12 gives a summary of the cost implication of providing steady electricity to the sub-grids using conventional methods of diesel generators and utility grid in one (1) year

Table 3.12: Cost of Providing Steady Electricity to the Sub-grids for one (1) year from Conventional sources of Utility grid and Diesel generator

Conventional Electricity Sources	SPGS Sub-grid	LAW Sub-grid	LIB Sub-grid	ENG Sub-grid
Annual Utility Grid (EEDC) Cost (NGN)	2,749,907.76	10,615,218.00	21,982,190.00	6,739,886.26
Annual Diesel cost for Diesel Generators (NGN)	10,377,201.00	51,885,999.00	103,771,998.00	38,395,639.26
Operation and Maintenance (O&M) cost (10% of fueling Cost) (N)	1,037,720.10	5,188,599.90	10,377,199.80	3,839,563.93
Total (N)	14,154,828.86	67,689,816.9	136,131,387.8	48,975,089.45
Grand Total = N266,961,123.01				

3.5 Design and Dimensioning of the Distributed Energy Sources (DES) for the Sub-grids

HOMER grid software simulation tool was used to simulate the various sub-grids using their load profiles, in order to obtain the optimized dimensioning of the DES. Taking the SPGS sub-grid as a case study, the steps to the simulation using HOMER grid are as follows:

- Setup the MG to be simulated. In the setup page, the location of the project is indicated to enable the software obtain the real life solar resources for that specific location, in order to accurately calculate the various components needed for the MG. The MG's name, author, a brief description of the MG, inflation rate, discount rate and the project life time are also taking care of at the setup page. The setup page for the SPGS sub-grid is shown in figure 3.9.
- The next step is to select a load profile category that best suit the MG to be simulated. Four major categories are made available, which are the Residential, Commercial, industrial and Community load profile categories. For the MG design for the SCHMG, commercial category was selected. Under the commercial load profile, a sample 60 minutes step 24-hour load profile format was provided. The provided sample load profile was adjusted based on the results of electrical load estimation at the sub-grids.
- Then all the required components of the sub-grid were added, namely, the utility grid, the solar PV, the BESS, the diesel generator and the converter.

- The final step is to simulate the MG to obtain the optimized solution for the sub-grid. The results would give the size of diesel generator if a fixed sized was not selected, the PV-module size in kW, the BESS stings, and the converter size. Screen shots of the simulation stages are shown in figures 3.10 and 3.11. HOMER Grid simulated more than 1000 possible combinations of the chosen energy sources and suggested the most optimized combination based on reduced Net Present Cost (NPC) and annual operating cost.

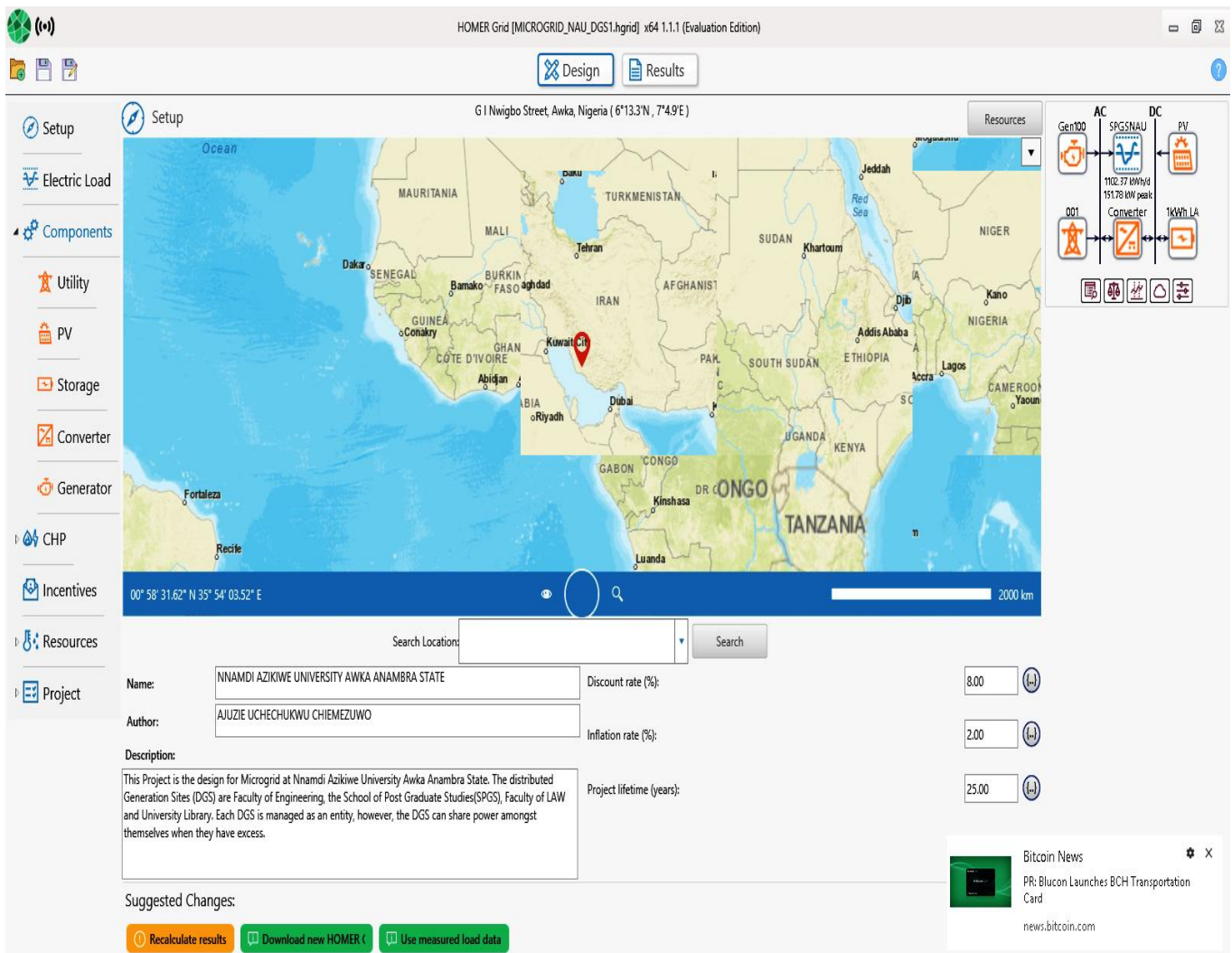

Figure 3.10: The Setup Page in HOMER grid

HOMER Grid [MICROGRID_NAU_DGS1.hgrid]* x64 1.1.1 (Evaluation Edition)

Design Results

Tables Graphs

Compare Economics Column Choices...

Export Optimization Results Categorized Overall

Left Double Click on a particular system to see its detailed Simulation Results.

Architecture				Cost				System			Compare	
PV (kW)	Gen100 (kW)	1kWh LA	001	Converter (kW)	NPC (US\$)	COE (US\$)	Operating cost (US\$/yr)	Initial capital (US\$)	Ren Frac (%)	Total Fuel (L/yr)	IRR (%)	Sim
			1		\$644,998	\$0.124	\$49,893	\$0.00	0	0		
	0.000911							2,901	0.000282	0		
		1						322.27	0	0		
	0.286	1						3,376	0.0885	0		
			100					40,000	0	0		
	0.000911							42,901	0.000282	0		
		1	1	0.0742	\$680,687	\$0.131	\$49,593	\$40,322	0	0		
	0.286	100	1	0.269	\$683,194	\$0.131	\$49,493	\$43,376	0.0885	0		

HOMER is optimizing for lowest net present cost...

29
#0
\$675,655

Cancel

Suggested Changes:

Recalculate results Use measured load data Optimization Report

Figure 3.11: Simulation in Progress

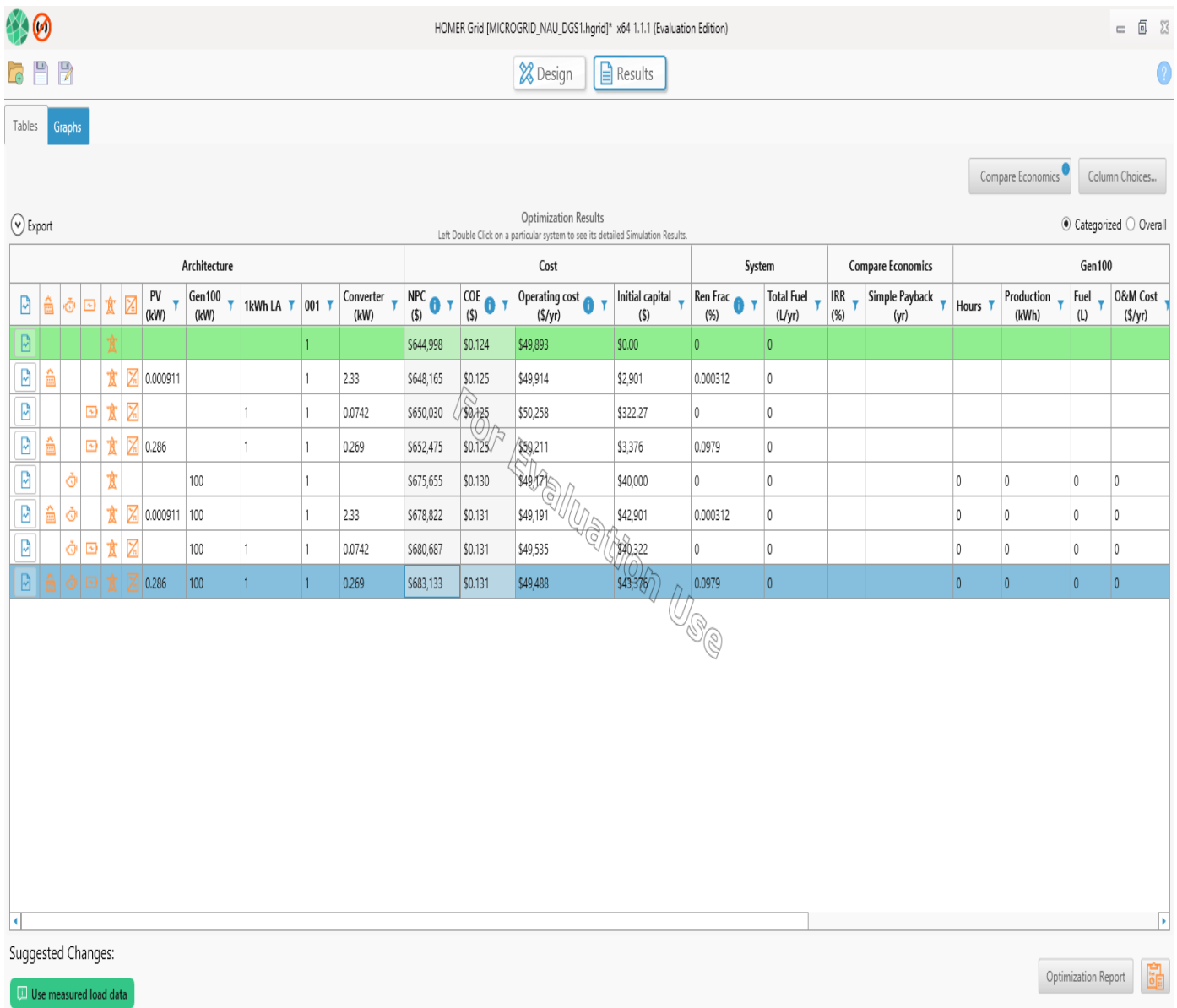

Figure 3.12: Simulation Results.

The component size requirements for SPGS, LAW, LIB and ENG Sub-grids obtained from simulation results are as shown in Table 3.13 to 3.16.

3.5.1 Simulation Results for SPGS Sub-grid

Figure 3.12 shows the schematic representation of the SPGS sub-grid, while table 3.13 summarizes the result of the simulation of SPGS load profile using the HOMER grid software.

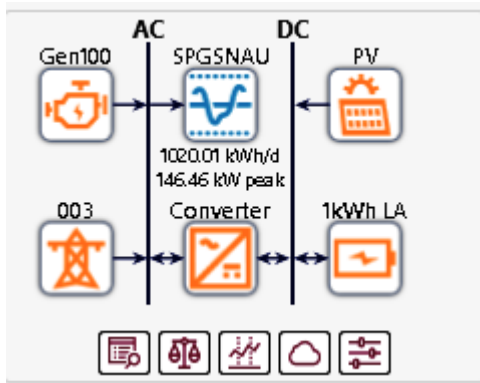

Figure 3.13: Schematic representation of the SPGS Sub-grid

Table 3.13: Component Requirements for SPGS Sub-grid Obtained from Simulation

Component	Name	Size	Unit
Generator	`Generic Medium Gen. Set (Size your own)	100	kW
PV	Generic Flat PV	295	kW
Storage	Generic 1kWh Lead Acid	52	String
System Converter	System Converter	145	kW
Dispatch Strategy	Homer Peak Saving		
Utility	Commercial		

3.5.2 Simulation Results for LAW Sub-grid

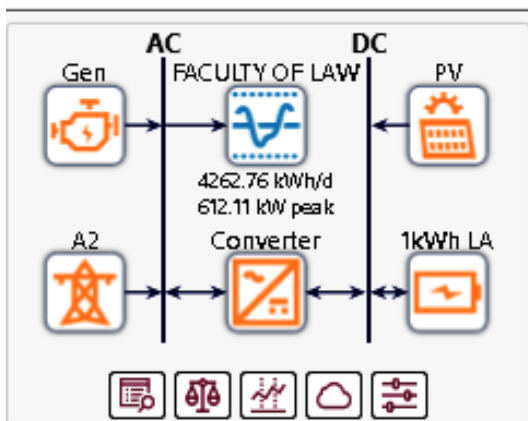

Figure 3.14 Schematic representation of LAW Sub-grid

Table 3.14: Component Requirements from the Simulation report of LAW Sub-grid

Component	Name	Size	Unit
Generator	`Generic Medium Gen. Set (Size your own)	620	kW
PV	Generic Flat PV	1,248	kW
Storage	Generic 1kWh Lead Acid	336	String
System Converter	System Converter	525	kW
Dispatch Strategy	Homer Peak Saving		
Utility	Commercial		

3.5.3 Simulation Results for LIB Sub-grid

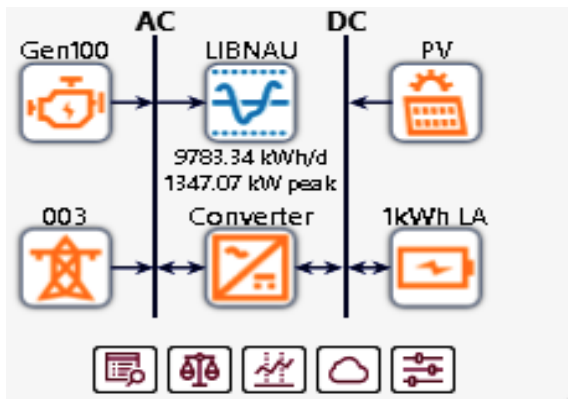
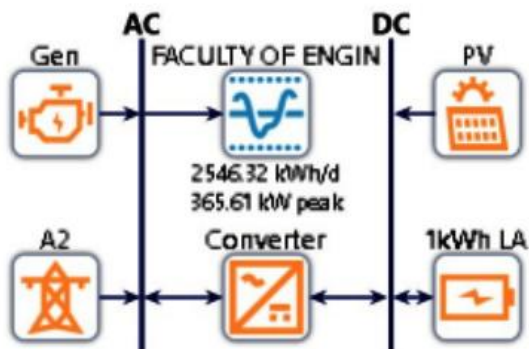

Figure 3.15: Schematic representation of LIB Sub-grid

Table 3.15: Component Requirements from the Simulation report of LIB Sub-grid

Component	Name	Size	Unit
Generator	`Generic Medium Gen. Set (Size your own)	1400	kW
PV	Generic Flat PV	3071	kW
Storage	Generic 1kWh Lead Acid	608	String
System Converter	System Converter	1200	kW
Dispatch Strategy	Homer Peak Saving		
Utility	Commercial		

Schematic



3.5.4 Simulation Results for ENG Sub-grid

Figure 3.16 Schematic representation of ENG Sub-grid

Table 3.16: Component Requirements from the Simulation report of ENG Sub-grid

Component	Name	Size	Unit
Generator	Generic Medium Gen. Set (Size your own)	370	kW
PV	Generic Flat PV	807	kW
Storage	Generic 1kWh Lead Acid	162	String
System Converter	System Converter	395	kW
Dispatch Strategy	Homer Peak Saving		
Utility	Commercial		

3.5.4 Deductions from HOMER Grid Results.

3.5.4.1 Operating Cost for using SCHMG for the Sub-grids

The operating cost of the running the four sub-grid by the SCHMG is supplied by the simulation results from HOMER Grid simulation software as follows; for the SPGS sub-grid NGN393,835 annually, for LAW sub-grid NGN1,910,045 annually, for the LIB sub-grid NGN3,900,755 annually and for the ENG sub-grid NGN850,070 annually. This is expected because most of the energy demanded by the various sub-grids will be supplied from the renewable source of solar-PV, which is readily available at no extra cost. This cost covers the additional cost of running the diesel generators during system maintenance, cloudy weather conditions and any occasion of system downtime. The amount of money that will be saved annually by the SCHMG for SPGS, LAW, LIB and ENG sub-grids will be NGN4,166,254.76, NGN17,754,654.10, NGN34535037.20 and NGN12,586432.27 respectively a total of NGN69,042,378.33 annually. Table 3.17 below presents the comparism between the annual cost of running the sub-grids solely on conventional sources of diesel generators and public utility and that of the SCHMG.

Table 3.17: Annual operating Cost Comparism between Conventional Sources and the SCHMG

Annual Operating Cost (NGN)	SPGS	LAW	LIB	ENG
Conventional Sources	NGN14,154,828.86	NGN67,689,816.90	NGN136,131,387.80	NGN48,975,089.45

SCHMG	NGN393,835.00	NGN1,910,045.00	NGN3,900,755.00	NGN850,070.00
Savings by Sub-grids	NGN13,760,993.86	NGN65,779,771.90	NGN132,230,626.80	NGN48,125,019.45
Total Saving	NGN254,896,412.01 annually			

3.5.4.2 Sizing Analysis based of HOMER Grid Simulation Results for the Sub-grids

The converter dc input voltage will determine the arrangement of the battery banks.

Assuming the dc voltage input of the converter is 240 V dc, the arrangement of the BESS is achieved as follows

$$\text{Converter input Voltage}(V_{CONV}) = 240V$$

$$B_S = V_{CONV} \div V_B \quad (3.5)$$

Where V_B = Voltage of a single lead acid battery = 12 V dc and B_S = the number of batteries in series.

$$B_S = 240V \div 12 V = 20 \text{ batteries in series.}$$

This implies that each battery bank will have 20 batteries connected in series.

$$B_T = B_S \times B_P \quad (3.6)$$

Where B_T is the total number of batteries that make up the BESS, B_S is the number of batteries connected in Series and B_P is the number of series banks batteries connected in parallel.

Therefore, the number of series bank to be connected in parallel (B_P) is given as

$$B_P = B_T \div B_S$$

Likewise, for the PV module arrangement, the series bank arrangement of the PV modules required to charge the 20 batteries in series is 10, since each PV module should charge 24V, that is, two batteries in series.

Therefore, the number of parallel bank of PV-module is given by (3.7)

$$PV_P = PV_T \div PV_S \quad (3.7)$$

Where PV_P is the number of series bank connected in Parallel, PV_T is total number of PV modules as provided by HOMER grid software and PV_S is the number PV modules connected in series

Also for the required solar charge controllers

The short circuit current on one solar PV module of rating, 300W, 36V can be deduced from (3.8)

$$P_U = V_U \times I_U \quad (3.8)$$

Where P_U is the power of a unit PV module, V_U is the voltage on a unit PV module and I_U is the short circuit current on a unit PV module

$$I_U = P_U \div V_U = 300W \div 36 = 8.33A$$

For the ten (10) PV modules connected in series, the same current flows through them.

Therefore the cumulative PV module current I_{PV} for each sub-grid can be calculated by multiplying I_U by the number of PV parallel bank (PV_P)

Thus

$$I_{PV} = I_U \times PV_P \quad (3.9)$$

In addition, the cumulative current of all the charge controllers (I_{SCC}) is given by

$$I_{SCC} = 1.2 \times I_{PV} \quad (3.10)$$

Also, the number of charge controllers required for the parallel banks (N_{SCCP}) is given by

$$N_{SCCP} = I_{SCC} \div I_{SU} \quad (3.11)$$

Where I_{SU} is the unit current rating of the charge controller

I_{SCC} is the total current of all the solar charge controllers

N_{SCC} is the number of solar charge controllers required for the parallel banks

However, solar charge controllers also has maximum voltage rating which determines how many will be connected in series. Assuming the voltage rating of a charge controller is V_{SCC} , then the number solar charge controllers, connected in series will be give by (3.12)

$$N_{SCCS} = V_{CONV} \div V_{SCC} \quad (3.12)$$

Where N_{SCCS} is the number of solar charge controllers connected in series.

V_{CONV} is the converter input voltage which is also the cumulative voltage of the batteries in series (B_S)

Therefore, the total number of charge controllers required is given by (3.13)

$$N_{SCCT} = N_{SCCS} \times N_{SCCP} \quad (3.13)$$

In addition, the importance of calculating the accurate size of conductor to be used for interconnection between the PV modules and BESS cannot be overemphasized. This is because the size of cables used for connection between the PV modules and the battery banks can introduce a huge amount of energy losses if it is not properly calculated, bearing in mind that DC voltage is being transported at this stage. The standard practice is to try and keep the cable length as short as possible.

The cable sizes for the interconnection of the BESS to the PV modules at different sub-grids are calculated as follows;

Using Ohm's Law

$$R = V/I \quad (3.14)$$

$$\text{Also,} \quad R = \rho \frac{L}{A} \quad (3.15)$$

Where L is the length of cable, A is the cross sectional area, R is the resistance of the cable and ρ is the resistivity of the cable.

Substituting (3.15) into (3.14) gives

$$V/I = \rho \frac{L}{A} \quad (3.16)$$

$$\text{But} \quad \rho = 1/\delta \quad (3.17)$$

Where δ is the conductivity of the cable.

Therefore, equation 3.16 becomes

$$V/I = \frac{1}{\delta} \times \frac{L}{A} = \frac{L}{Ax \delta}$$

Therefore $A = \frac{LI}{V\delta}$ (3.18)

L is the length of both the positive and negative wires,

Therefore

$$L = 2l$$
 (3.19)

Where l is the distance between the PV modules and the BESS.

Substituting (3.19) into (3.18)

$$A = \frac{2l \times I}{V \times \delta}$$
 (3.20)

V is the allowable voltage drop for efficient connection and loss minimization which is usually expressed as a percentage of the system voltage, which is the converter voltage. (Note

$$V_S = V_{CONV})$$

$$V = X\% \text{ of } V_{CONV}$$
 (3.21)

Therefore

The cross sectional area of the wire A is given as

$$A = \frac{(2l \times I)}{\left(\frac{X}{100}\right) \times V_{CONV} \times \delta}$$
 (3.22)

or $A = \frac{(200 \times l \times I)}{(X \times V_{CONV} \times \delta)}$ (3.23)

3.5.4.2.1 SPGS Sub-grid

From Table 3.13 HOMER grid specified 295kW solar PV module bank for the SPGS sub-grid. Using Solar PV modules rated at 300W, 36V each, the required number of modules IS given by

$$295000W \div 300W = 983.33 \approx 984 \text{ pieces}$$

The required BESS is 52 pieces of 200AH, 12V lead-acid batteries

While the required converter is 145kW

Assuming the dc voltage input of the converter is 240 V dc, this implies that 20 batteries must be connected in series as converter dc input voltage.

$$B_S = 20 \text{ batteries}$$

$$B_T = 52 \text{ batteries}$$

From (3.6)

$$B_T = B_S \times B_P$$

$$B_P = 52 \div 20 = 2.6 \approx 3 \text{ parallel banks.}$$

Total number of batteries required (B_T) is now = $20 \times 3 = 60$ batteries, instead of 52 batteries. This little adjustment is important to balance the battery bank.

PV module arrangement,

For SPGS sub-grid,

$$PV_T = 984 \text{ PV modules, } PV_S = 10 \text{ PV modules}$$

$$PV_P = 984 \div 10 = 98.4 \approx 95 \text{ parallel banks}$$

Therefore

$$PV_T \text{ is now adjusted to } 95 \times 10 = 950 \text{ pieces of 300W, 36V PV modules}$$

Number of Solar, Charge Controllers (SCC)

$$PV_P = 95 \text{ parallel banks}$$

$$I_U = 8.33\text{A}$$

From (3.9),

$$I_{PV} = 95 \times 8.33 = 791.35\text{A}$$

But from (3.10)

$$I_{SCC} = 1.2 \times 791.35 \text{ A} = 949.62\text{A}$$

Also from (3.11) using an MPPT 60A, 48V solar charge controller,

$$N_{SCCP} = 949.62\text{A} \div 60 = 15.827 \approx 16 \text{ parallel solar charge controller}$$

From (3.12) , N_{SCCS} was calculated as shown

$$N_{SCCS} = 240 \div 48 = 5 \text{ solar charge controller connected in series.}$$

(3.13) gives the total number of required solar charge controllers (N_{SCCT})

$$N_{SCCT} = 5 \times 16 = 80 \text{ pieces of 60A, 48V Maximum Power Point Tracking (MPPT) solar charge controller.}$$

Cable Sizing

Assuming 10meters cable length between the PV modules and the BESS

Using (3.23), the cross sectional area of the required cable A is given by

$$A = \frac{(200 \times l \times I)}{(X \times V_{\text{CONV}} \times \delta)}$$

$l = 10\text{m}$, $I = I_{\text{PV}} = 791.35\text{A}$, $X = 5$, $\delta = 56$ (for copper), $V_s = V_{\text{CONV}} = 240\text{V}$

$$A = \frac{(200 \times 10 \times 791.35)}{(5 \times 56 \times 240)} = 23.552 \approx 24 \text{ mm}^2$$

$$A = 23.552 \text{mm}^2 \approx 24 \text{mm}^2$$

However, 25mm^2 is readily available in the market.

3.5.4.2.2 LAW Sub-grid

In the same way, from Table 3.14, the requirements for the LAW sub-grid are as follows:

The number required PV modules = $1,248,000\text{W} \div 300\text{W} = 4160\text{pcs}$

The required BESS is 336 pieces of 200AH, 12V

Converter Size = 525kW.

The required BESS is 336 pieces of 200AH, 12V lead-acid batteries

While the required converter is 525kW

Assuming that the dc voltage input of the converter is 240 V dc, this implies that 20 batteries must be connected in series as converter dc input voltage.

$B_S = 20$ batteries

$B_T = 336$

From (3.6),

$B_P = B_T \div B_S = 336 \div 20 = 16.8 \approx 17$ Parallel banks

Therefore B_T is adjusted to

$B_T = 17 \times 20 = 340$ pieces of 200AH 12V, Lead acid batteries

PV module arrangement

$PV_T = 4160$ pieces of 300W, 36V PV modules

$PV_S = 10$ pieces

Therefore using (3.7)

$PV_P = 4160 \div 10 = 416$ parallel banks of solar PV modules.

Solar Charge Controllers

$PV_P = 416$ parallel banks

$I_U = 8.33\text{A}$

From (3.9),

$$I_{PV} = 416 \times 8.33 = 3465.28A$$

But using (3.10),

$$I_{SCC} = 1.2 \times 3,465.28 A = 4,158.336A$$

Also from (3.11) using an MPPT 60A, 48V solar charge controller,

$$N_{SCCP} = 4,158.336A \div 60A = 69.3056 \approx 70 \text{ parallel solar charge controller}$$

From (3.12), N_{SCCS} is calculated as

$$N_{SCCS} = 240 \div 48 = 5 \text{ solar charge controller connected in series.}$$

From (3.13), the total number of required solar charge controllers (N_{SCCT}) is given by

$$N_{SCCT} = 5 \times 70 = 350 \text{ pieces of 60A, 48V MPPT solar charge controller.}$$

Cable Sizing

Assuming 10meters cable length between the PV modules and the BESS

Deploying (3.23), the cross sectional area of the required cable A is given by

$$A = \frac{(200 \times l \times I)}{(X \times V_{CONV} \times \delta)}$$

$$l = 10m, I = I_{PV} = 3465.28A, X = 5, \delta = 56, V_s = 240V$$

$$A = (200 \times 10 \times 3465.28) / (5 \times 56 \times 240) = 103.133mm^2$$

$$A = 103.133mm^2 \approx 104 mm^2$$

Note: This size of cable can easily be achieved by combining several smaller sizes readily available in the market if it is not readily available.

3.5.4.2.3 LIB Sub-grid

Also from Tables 3.15, the requirements for LIB sub-grid are as shown as follows:

$$\text{The number required PV modules} = 3,071,000W \div 300W = 10236.66 \text{ pcs} \approx 10237 \text{ pcs}$$

The required BESS is 608 pieces of 200Ah, 12V lead-acid deep cycle batteries.

$$\text{Converter Size} = 1200kW.$$

Assuming the dc voltage input of the converter is 240 V dc, this implies that 20 batteries must be connected in series as converter dc input voltage.

$$B_S = 20 \text{ batteries}$$

$$B_T = 608$$

From (3.6) , it is given that

$$B_P = B_T \div B_S = 608 \div 20 = 30.4 \approx 31 \text{ Parallel banks}$$

Therefore B_T is adjusted to

$$B_T = 31 \times 20 = 620 \text{ pieces of 200AH 12V, Lead acid batteries}$$

PV module arrangement

$$PV_T = 10237 \text{ pieces of 300W, 36V PV modules}$$

$$PV_S = 10 \text{ pieces}$$

Therefore from (3.7),

$$PV_P = 10237 \div 10 = 1023.7 \approx 1024 \text{ parallel banks of solar PV modules.}$$

Therefore PV_T is adjusted to

$$PV_T = 1024 \times 10 = 10240 \text{ pieces of 300W, 36V PV modules}$$

Solar Charge Controller

$$PV_P = 1024 \text{ parallel banks}$$

$$I_U = 8.33A$$

Using (3.9),

$$I_{PV} = 1024 \times 8.33 = 8529.92A$$

But from (3.10),

$$I_{SCC} = 1.2 \times 8529.92A = 10,235.904A$$

Also from (3.11), using an MPPT 60A, 48V solar charge controller,

$$N_{SCCP} = 10,235.904A \div 60A = 170.5984 \approx 171 \text{ parallel solar charge controller}$$

From (3.12), N_{SCCS} can be calculated as follows;

$$N_{SCCS} = 240 \div 48 = 5 \text{ solar charge controller connected in series.}$$

From (3.13), the total number of required solar charge controllers (N_{SCCT})

$$N_{SCCT} = 5 \times 171 = 855 \text{ pieces of 60A, 48V MPPT solar charge controller.}$$

Cable Sizing

Assuming 10meters cable length between the PV modules and the BESS

Using (3.23), the cross sectional area of the required cable A is given by

$$A = \frac{(200 \times l \times I)}{(X \times V_{CONV} \times \delta)}$$

$$l = 10m, I = I_{PV} = 8529.92A, X = 5, \delta = 56, V_s = 240V$$

$$A = (200 \times 10 \times 8529.92) / (5 \times 56 \times 240) = 253.867mm^2$$

$$A = 253.867mm^2 \approx 254mm^2$$

3.5.4.2.4 ENG Sub-grid

From Table 3.16 the requirements for ENG sub-grid are as shown as follows:

Number of PV modules required = $80700W \div 300W = 2690\text{pcs}$

Required BESS = 162 pieces of 12V, 200AH, lead-acid batteries

While the converter = 395kW.

Assuming the dc voltage input of the converter is 240 V dc, this implies that 20 batteries must be connected in series as converter dc input voltage.

$B_S = 20$ batteries

$B_T = 162$ pieces of 200AH, 12V lead-acid batteries

From (3.6) ,

$B_P = B_T \div B_S = 162 \div 20 = 8.1 \approx 8$ Parallel banks

Therefore B_T is adjusted to

$B_T = 8 \times 20 = 160$ pieces of 200AH 12V, Lead acid batteries

PV module arrangement

$PV_T = 2690$ pieces of 300W, 36V PV modules

$PV_S = 10$ pieces

Therefore from (3.7) ,

$PV_P = 2690 \div 10 = 269$ parallel banks of solar PV modules.

Solar Charge Controller

$PV_P = 269$ parallel banks

$I_U = 8.33\text{A}$

Applying (3.9),

$I_{PV} = 269 \times 8.33 = 2240.77\text{A}$

But using (3.10),

$I_{SCC} = 1.2 \times 2,240.77 \text{ A} = 2,688.924\text{A}$

Also from (3.11), using an MPPT 60A, 48V solar charge controller,

$N_{SCCP} = 2,688.924\text{A} \div 60\text{A} = 44.8154 \approx 45$ parallel solar charge controller

Also deploying (3.12), N_{SCCS} was calculated using

$N_{SCCS} = 240 \div 48 = 5$ solar charge controller connected in series.

From (3.13), the total number of required solar charge controllers (N_{SCCT})

$N_{SCCT} = 5 \times 45 = 255$ pieces of 60A, 48V MPPT solar charge controller.

Cable Sizing

Assuming 10meters cable length between the PV modules and the BESS

From (3.23), the cross sectional area of the required cable A is given by

$$A = \frac{(200 \times l \times I)}{(X \times V_{CONV} \times \delta)}$$

$l = 10\text{m}$, $I = I_{PV} = 2240.77\text{A}$, $X = 5$, $\delta = 56$, $V_s = 240\text{V}$

$A = (200 \times 10 \times 2240.77\text{A}) / (5 \times 56 \times 240) = 66.6895\text{mm}^2$

$A = 66.6895\text{mm}^2 \approx 70\text{mm}^2$

Table 3.18: Summary of Component Requirements for the Sub-grids

Sub-grids	Batteries (200AH , 12 V)			PV Modules 300W/36V			Converter and Charge Controllers		Cable Size mm ²
	Parallel Banks (B _P)	Series Banks (B _S)	Total (B _T)	Parallel Banks (PV _P)	Serial Banks (PV _S)	Total (PV _T)	Converter (kW)	Solar Charge Controller	
LAW	17	20	340	416	10	4160	525	350	104
SPGS	3	20	60	95	10	950	145	80	25
LIB.	31	20	620	1024	10	10240	1200	855	254
ENG.	8	20	160	269	10	2690	395	255	70
Total			1180			18040		1540	

Table 3.20 Net Present Cost (NPC) implication for the sub-grids

Sub-grids	Batteries (12V, 200AH deep cycle batteries) Unit price N130,000		PV Modules (300W PV Modules) Unit price N65,000		Inverter and Charge Controllers (500kVA inverter = N150,000,000) 60A MMPT charge controller = N170,000			
	QTY	Cost (N)	QTY	Cost (N)	Inverter (kW) (Qty)	Cost (N)	QTY of SCC	Cost (N)
LAW	340	44,200,000	4160	270,400,000	525	153,000,000	350	59,500,000
SPGS	60	7,800,000	950	61,750,000	145	40,000,000	80	13,600,000

LIB.	620	80,600,000	10240	665,600,000	500 x 2	300,000,000	855	145,350,000
ENG.	160	20,800,000	2690	174,850,000	395	87,000,000	255	43,350,000
TOTAL	1180	153,400,000 (NGN)	18040	1,172,600,000 (NGN)	580,000,000 (NGN)		1540	261,800,000 (NGN)

3.6 Load Analysis and Categorization

The estimated electrical loads for the sub-grids are broadly divided into two major types namely;

Day Loads (P_d) in kW and Night Loads (P_n) in kW.

Day Loads are the electrical loads that are used during the day only, while the night loads are loads used during the nights only.

Where (P_d) is the summation of the wattages of appliances and any other form of electrical loads in kW used during the day, between 8.00am to 7.00pm.

(P_n) is the summation of the wattages of electrical loads in kW used in the night between, 7pm to 8am.

Therefore

$$P_d = \sum_1^n (P_{dn}) \quad (3.24)$$

$$P_d = P_{d1} + P_{d2} + P_{d3} + \dots + P_{dn} \quad (3.25)$$

Also for the electrical loads used in the night (P_n)

$$P_n = \sum_1^m (P_{nm}) \quad (3.26)$$

$$P_n = P_{n1} + P_{n2} + P_{n3} + \dots + P_{nm} \quad (3.27)$$

All the electrical loads at the various sub-grids are further categorized into three major categories, which are high priority (hpl), priority loads (pl) and less priority loads (lpl), based on their priority.

The night electrical loads (P_n) are majorly security lighting systems and other security gadgets; hence they are all high priority loads (**hpls**). The electrical loads used during the day, termed day electrical loads (P_d), are further categorized into High priority loads (**hpl**), Priority loads (**pl**) and Less priority loads (**lpl**). At this point the load Management planning is executed. Load management is possible at this level because microgrid employ distributed generation (DG) not bulk generation. In distributed generation, electricity is generated close to the load, so there is no need for long distance transmission and consequent distribution as the case with bulk generation. Rather, in distributed generation, the DG bus is tied to the loads directly. See Appendix D.

3.6.1 High Priority Loads

High Priority loads (P_d) **hpl** are the electrical loads that are critical and must be supplied with power whenever they need it, no matter the status of the microgrid. The appliances that fall within this category are internet modems, computers, printers, photocopiers, public address system, water pumping machines, office lightings, ceiling fans. All the electrical loads in some sensitive offices are also categorized under **hpls**. Also all night loads which include security lighting system and other security gadgets are categorized under **hpls**. The **hpls** were selected based on the important roles they play in each sub-grid.

3.6.2 Priority Loads

Priority loads (P_d) **pl** are loads that should be supplied with power once the **hpls** have enough and the available power within the sub-grid is enough to supply them. They include air conditioners and water dispensers.

3.6.3 Less Priority Loads

Less Priority loads (P_d) **lpl** are loads that are supplied when the power generated by sub-grid is enough to supply the entire electrical load within the sub-grid. Examples of such loads are TVs, refrigerators, deep freezers. However, the sub-grids are actually designed in such a way that, at any point in time the solar energy generated should be able to supply all the load categories, but whenever there is shortage in the generated solar energy within each sub-grid, an intelligent load shedding protocol is invoked by the Local intelligent Agent (LIA).

The categorizations of the loads are subject to amendment depending on priority of each sub-grid.

3.7 Mathematical Representation of the Load categorisation of the Sub-grids

From the above categorisation, the total wattage of the electrical loads used during the day (P_d) for each of the sub-grids can be represented mathematically as shown in (3.28).

$$P_d = P_{d(hpl)} + P_{d(pl)} + P_{d(lpl)} \quad (3.28)$$

For Night Loads, since they are all high priority loads (hpls)

so

$$P_n = P_{n(hpl)} \quad (2.29)$$

There the total load demand for each sub-grid is mathematically given by

$$P_{total} = P_d + P_n \quad (2.30)$$

3.7.1 Analysis on the SPGS Sub-grid as a case Study

Based on the results of the load estimation done at the sub-grid using (2.30),

$$P_{total} = P_d + P_n = 93.425kW$$

$$P_d \approx 87.925kW, \quad \text{While} \quad P_n \approx 5.5kW$$

It is obvious that more electrical loads are used during the day than at night. That is an advantage, since one of the major and cost efficient energy sources to the SCHMG is the solar energy which is readily available during the day.

Mathematically,

$$P_d > P_n \quad (3.31)$$

Let energy Demand during the day be denoted by $E_{dem(day)}$, while the energy demand during the night is represented by $E_{dem(night)}$.

Assuming all the installed electrical loads are in use, then the energy demand in the night is giving by

$$E_{dem(night)} = P_n \times T_{night} \quad \text{in kWh} \quad (3.32)$$

But $P_n = 5.5kW$, while $T_{night} = (7pm \text{ to } 7am) = 12Hrs$

Therefore

$$E_{\text{dem (night)}} = 5.5\text{kW} \times 12\text{hrs} = 66\text{kWh of Energy}$$

Also

$$E_{\text{dem (day)}} = P_d \times T_{\text{day}} \text{ in kWh} \quad (3.33)$$

$$\text{But } P_d = 87.925\text{kW}, T_{\text{day}} = (8\text{am to } 5\text{pm}) = 9\text{hrs}$$

Assuming all electrical loads will be in use at the same time,

$$E_{\text{dem (day)}} = 87.925\text{kW} \times 9\text{hrs} = 791.325\text{kWh of Energy}$$

However, the assumption that all the loads will be used for the same duration is not obtainable in reality. In practice, the Energy demand will be variable depending on the loads that are being used at any giving time.

In summary, the solar plant for each site should be able to supply $E_{\text{dem (day)}}$ during the day and reserve (store up) $E_{\text{dem (night)}}$ for the night loads.

The design took into consideration of the average optimal sun hours, which is approximately 5 hours daily (Augustine & Nnabuchi, 2009),

So the solar plant for each sub-grid should be able to harvest ($E_{\text{dem (day)}} + E_{\text{dem (night)}}$) within 5hours.

These analysis enhanced the accuracy of the design decisions that was taken within each sub-grid.

$$E_{\text{dem (day)}} = 791.325\text{kWh of Energy}$$

$$\text{While } E_{\text{dem (night)}} = 60\text{kWh of Energy}$$

The same analysis is applicable in all the other sub-grids.

3.8 Mathematical Model for the Total Energy demand (TE_{dem}) of each of the Sub-grids

The total energy demand (TE_{dem}) is the total energy each of the sub-grids within the microgrid requires to supply its loads for the desired hours of operation.

Therefore,

$$TE_{\text{dem}} = E_{\text{dem(day)}} + E_{\text{dem(night)}} \quad (3.34)$$

$$TE_{\text{dem}} = (P_n \times T_{\text{night}}) \text{ in kWh} + (P_d \times T_{\text{day}}) \text{ in kWh}$$

Representing TE_{dem} mathematically, the total energy consumption in a building with n numbers of loads for a period of time T is given by (Theraja and Theraja);

$$TE_{\text{dem}} = \sum_1^n \int_0^T (IVC \cos \theta) dt$$

(3.35)

Where

I = current drawn by the electrical loads per time t .

V = Voltage across the electrical loads.

$\text{Cos}\theta$ = power factor of the electrical load.

The loads are further grouped into two types namely Resistive and Reactive loads.

For resistive loads, $\text{Cos}\theta = 1$ while for Reactive loads $\text{Cos}\theta \neq 1$

Therefore,

$$\text{TE}_{\text{dem}} = \sum_1^Q \int_0^T (IV \text{Cos}\theta) dt + \sum_1^P \int_0^T (IV) dt \quad (3.36)$$

Where P is the total number of resistive loads being considered and Q is the total number of reactive loads being considered.

Let the power drawn by the resistive loads for time T be P_r and that of the reactive loads be P_c

Therefore

$$\text{TE}_{\text{dem}} = \sum_1^Q \int_0^T P_c dt + \sum_1^P \int_0^T P_r dt$$

Expanding the expression above we get

$$\begin{aligned} \text{TE}_{\text{dem}} = & P_{c1} \int_0^T dt + P_{c2} \int_0^T dt + \dots + P_{cQ} \int_0^T dt + P_{r1} \int_0^T dt + P_{r2} \\ & \int_0^T dt \\ & + \dots + P_{rP} \int_0^T dt \end{aligned} \quad (3.37)$$

(3.37) is the mathematical model for the total energy demand (TE_{dem}) of each sub-grid of the microgrids.

3.9 The Energy Management System (EMS) for the Smart Campus Hybrid Microgrid (SCHMG) in Nnamdi Azikiwe University

The major objective of the EMS is to ensure that the energy from the different energy input sources are systematically engaged in order to deliver a very reliable and steady energy supply to the different sub-grids at the cheapest rate possible. The EMSs monitors the energy coming from the solar-PV, the BESS State of Charge (SoC), the utility availability, the availability of the auxiliary energy source (AUX) and the readiness of the stand-by diesel generator. An energy management algorithm to ensure the achievement of the EMS objective was developed and implemented using dedicated intelligent agents called Local Intelligent Agents (LIAs). These intelligent agents are autonomous, though they can also interact with one another as the need arises.

3.9.1 The Local Intelligent Agents (LIAs)

The different sub-grids are managed by LIAs. The LIAs monitor the status of the different aspects of the sub-grids. They monitor the solar-PV, the SoC of the BESSs, the status of the converters, the status of utility grid, the diesel generators, and status of the Auxiliary energy to or from neighbouring sub-grids. It also ensures the delivery of steady, reliable and cost effective energy to different categories of loads within each sub-grid. At any point in time, the EMS manages the available energy within the sub-grid to ensure the delivery of a reliable, cost-effective and steady power supply within its sub-grid. The LIAs are responsible for triggering the automatic load shedding protocol in case of energy shortfalls within the sub-grids. They can engage or disengage one or more of the energy sources in order to realize their set objective. Figure 3.17 presents the high level description of a sub-grid. It clearly portrays the various energy input sources to the sub-grids, the LIA, the Auxiliary (AUX) power from or to neighbouring sub-grids and the different load categories at each sub-grid.

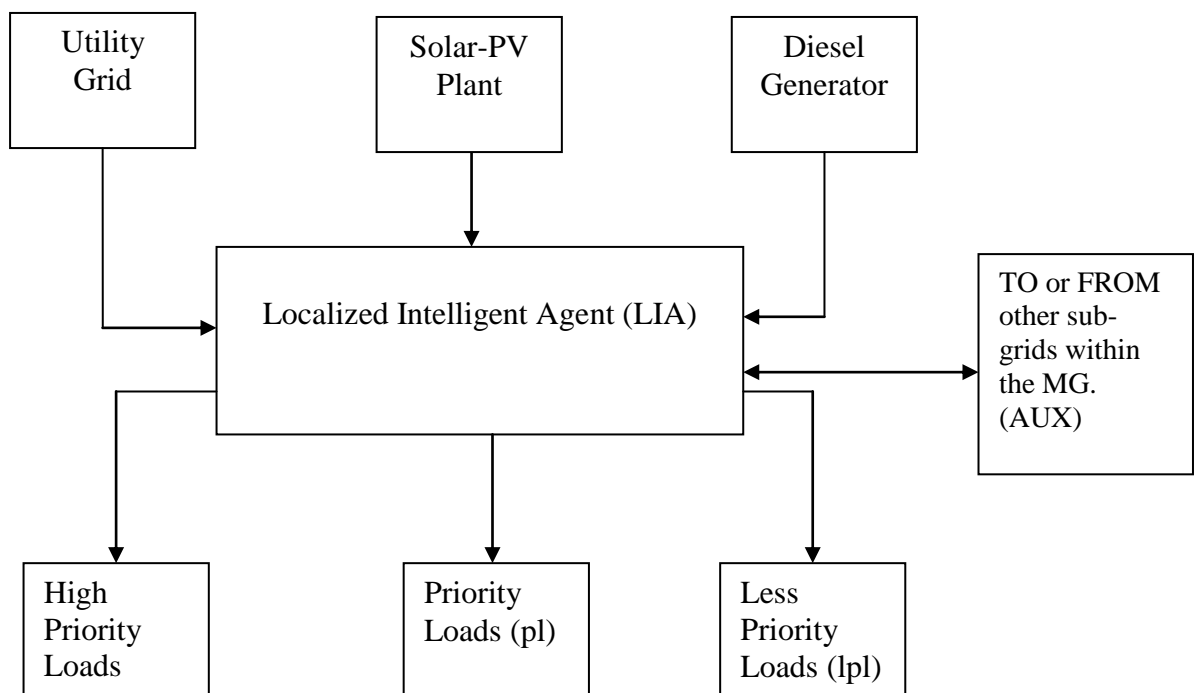

Figure 3.17: The High level description of the Sub-grids

The LIAs manage the available energy from the input sources within the each sub-grid. They take decisions on the category of loads to supply, based on some factors which include the solar-PV energy, the energy available within the sub-grid at any time. They also choose the

particular energy source to select for the efficient running of the sub-grid, when multiple energy input sources are available. For each of sub-grids, the following decisions were taken for ease of implementation.

- (i) The primary source of energy for the SCHMG is solar energy, the diesel generator is a backup energy source, engaged only when the solar energy is not sufficient to drive the high priority loads (**hpls**) or when routine maintenance is being carried out on the solar plant. The utility grid is switched ON, only if the solar-PV is not available, the AUX energy input is not available and the SoC of the BESS is too low to drive at least the high priority loads (hpls). The Diesel generator is switch ON only if the solar-PV, AUX input and the utility grid are not available.
- (ii) The energy available in each sub-grid is measured and critical control decisions are taken based on the results.
- (iii) The LIAs are furnished with appropriate fuzzy logic algorithm which enable them to take appropriate control decisions within the sub-grids.

3.9.1.2 Mathematical Model for the Energy Management System (EMS) of the Sub-grid

For each of the sub-grid to sustainably supply all their electrical load categories using the solar energy which is the primary energy input source, the energy available (E_{avb}) must be greater than the total energy demand of the sub-grid (TE_{dem}). The BESS is always engaged since the developed solar plant, runs on battery inverters (also called converters). However, if solar energy is available, as in the day time, as the energy is being drawn from the BESS, part or all of the energy drawn will also be replaced by the solar-PV.

Mathematically,

Energy Available (E_{avb}) > Total Energy Demand (TE_{dem})

That is

$$E_{avb} > TE_{dem} \quad (3.38)$$

But

$$TE_{dem} = E_{dem(hpl)} + E_{dem(pl)} + E_{dem(lpl)} \quad (3.39)$$

Where

$E_{dem(hpl)}$ = Energy demanded by High Priority Loads

$E_{dem(pl)}$ = Energy demanded by Priority Loads

$E_{dem(lpl)}$ = Energy demanded by Less Priority Loads

Assuming battery inverters only are used, then

E_{avb} = Energy Stored in the battery banks in kWh

Let the installed battery capacity be B_{inst} in kWh

The available battery capacity for use (Spotnitz, 2003)

$$B_{avb} = B_{inst} \times \text{DoD (Depth of Discharge)} \quad (3.40)$$

But

$$B_{avb} = E_{avb} \quad (3.41)$$

Since it is the exact amount of the stored energy that can be used

As the system begin to run, the battery begin to releases some of its stored energy (B_{rel}) as the loads draw current ($I_{disch.}$) in Amperes from the battery banks.

Therefore,

$$B_{rel} = I_{disch.} \times V_s \times T \quad (3.42)$$

Where

$I_{disch.}$ is the measured discharge current in Amperes.

V_s is the System Voltage in Volts.

However, at any point in time (t), that current ($I_{disch.}$) is being drawn from the battery banks, the battery energy remaining (B_{rem}) is given by

$$B_{rem} = B_{avb} - B_{rel} \quad (3.43)$$

(3.43) is applicable when there is no replacement from the photovoltaic (PV) modules, like in night scenarios, when there is no solar energy.

However, in the day time, as current (I_{disch}) is being drawn from the battery banks; solar energy replenishes some or all of the drawn current via (I_{charge}).

Where I_{charge} is the charging current (measured in Ampere) from the PV modules.

Therefore the energy being replaced back into the battery bank ($B_{rep.}$) is given by

$$B_{rep.} = I_{charge} \times V_p \times \text{Time} \quad (3.44)$$

Where V_p = Panel voltage

Therefore B_{rem} in the day when solar energy is available is given by

$$B_{rem} = B_{avb} - B_{rel} + B_{rep} \quad (3.45)$$

Thus for the energy from solar-PV, BESS and Battery inverters to be sustainable,

$$B_{rep} \geq B_{rel} \quad (3.46)$$

If $B_{rel} > B_{rep}$,

Then the solar energy supply to sub-grid will shutdown with time if nothing was done. That is, if there was no intelligent load shedding.

So at any point in time (t), the LIA monitors to ensure that

$$B_{rep} \geq B_{rel}$$

Else

Intelligent load shedding Protocol is initiated by the LIA in order to properly manage the available energy input resources.

3.9.1.3 The EMS Algorithm for Sub-grids

From (3.38) for the solar energy to supply all the load categories sustainably,

$E_{avb} > TE_{dem}$ must be TRUE

If $E_{avb} > TE_{dem}$ becomes false AND utility grid energy input is not available, THEN intelligent load shedding algorithm is initiated, to load shed some load categories.

However, if the utility grid is available, then all the load categories should be supplied from the utility grid, while the utility grid recharges the BESS.

3.9.1.4 Load Shedding Protocol Algorithm for the Sub-grids

IF $E_{avb} < TE_{dem}$ AND Utility Grid is available

THEN Supply $E_{dem(hpl)} + E_{dem(pl)} + E_{dem(lpl)}$

ELSEIF $E_{avb} < TE_{dem}$ AND Utility Grid is NOT available but $E_{avb} > E_{dem(hpl)} + E_{dem(pl)}$

THEN Load Shed $E_{dem(lpl)}$

ELSEIF $E_{avb} < E_{dem(hpl)} + E_{dem(pl)}$ AND Utility Grid is NOT available but $E_{avb} > E_{dem(hpl)}$

THEN Load Shed $E_{dem(lpl)}$ & $E_{dem(pl)}$

ELSIF $E_{avb} < E_{dem(hpl)} + E_{dem(pl)}$ & $E_{avb} < E_{dem(hpl)}$ AND Utility Grid is NOT available

THEN Check the Availability of the AUX. energy input

IF AUX is Available

THEN Supply only $E_{dem(hpl)}$ AND load shed $E_{dem(lpl)}$ & $E_{dem(pl)}$

ELSEIF AUX is NOT available

THEN switch to the Diesel Generator (GEN), AND supply $E_{dem(hpl)} + E_{dem(pl)} + E_{dem(lpl)}$

ELSIF $E_{avb} < E_{dem(hpl)} + E_{dem(pl)}$ & $E_{avb} < E_{dem(hpl)}$ AND Utility Grid is NOT available AND GEN is NOT Available

THEN shutdown the energy Supply to the Sub-grid, WHILE monitoring to know when any of the other energy inputs will be available.

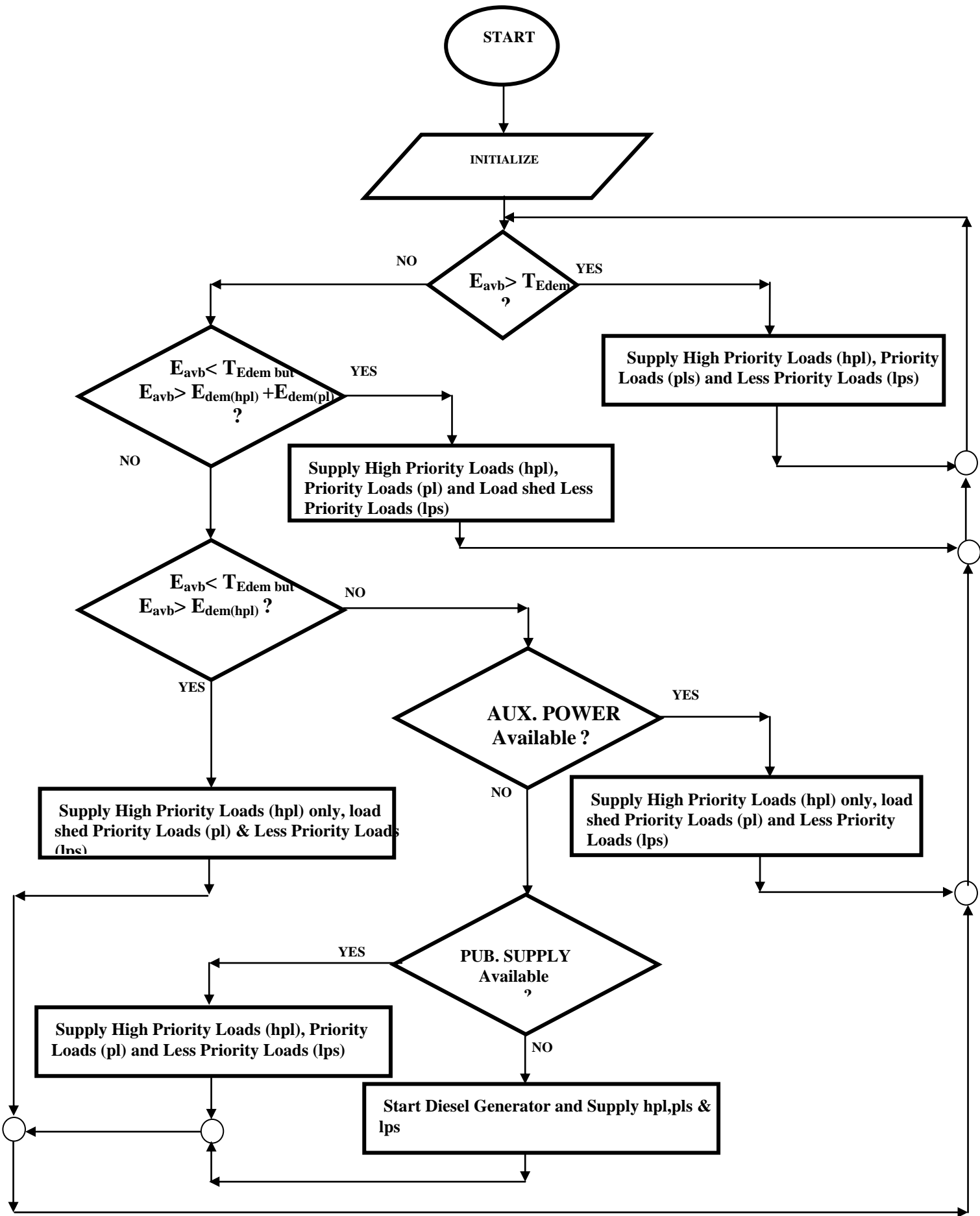

Figure3.18: The Flow chart for the LIA

Figure 3.18 presents the flow chart for the LIA. It clearly shows how the different energy input sources to the sub-grids are selected to supply the different load categories. The primary energy input source to the sub-grids being the solar energy and is renewable in nature is the cheapest source and thus overrides all the other energy sources once it is available and has enough energy to supply all the load categories. The utility grid supply is not engaged as long as there is enough solar energy within the sub-grid to supply all load categories, even when it is available. The diesel GEN serves as a standby source to the sub-grid, that is automatically engaged when, the solar energy is unable to supply at least the high priority loads, the AUX input is unavailable and the utility grid is also unavailable. This algorithm ensures a cost effective approach in the running of the sub-grids, while delivering a reliable and steady power supply. In this way, high efficiency in the management of available energy is ensured. The LIAs are autonomous intelligent agents and runs their various sub-grids in islanded modes, except when they have excess energy to give to or need extra energy from the sub-grids.

3.9.2 MATLAB Model of the LIA using FUZZY LOGIC Tool Box.

The Model development of the LIA was carried out with MatLab using the Fuzzy Logic tool box of Simulink. Figure 3.19 shows the membership functions for the model, which include the four input variables, (SOLAR, PUBSUPPLY, GEN and AUX) corresponding to the four energy input sources to the sub-grid, and the three output variables, (HIGH-P, PRIORITY and LOW-P) corresponding to the three electrical load categories within each sub-grid.

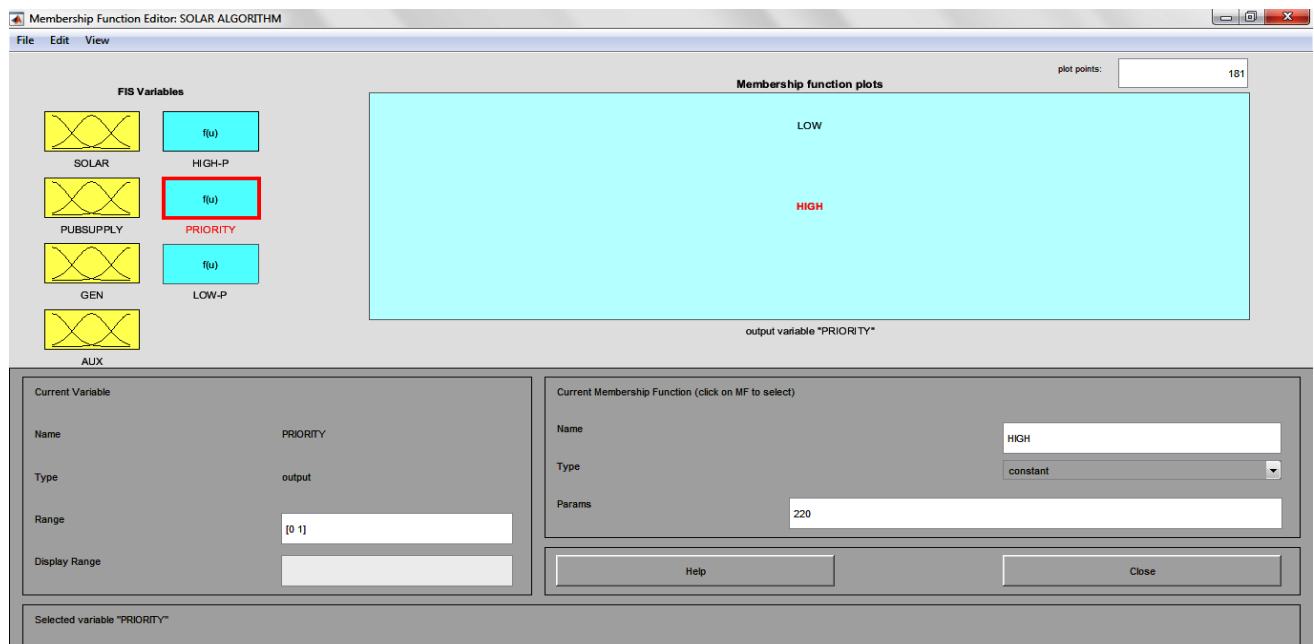

Figure 3.19: Membership Function for the LIA Fuzzy logic Implementation

In addition, Figure 3.20 shows the fuzzification of the solar plant. The fuzzification of the solar plant for the sub-grids was achieved by using the BESS State of Charge (SoC) is categorized into four categories between the range of 12V to 14V. These four SoC categories can be represented by fuzzy logic linguistic variable as follows; VERY LOW (12.1), LOW (12.5), HIGH (13) and VERY HIGH (13.5) states.

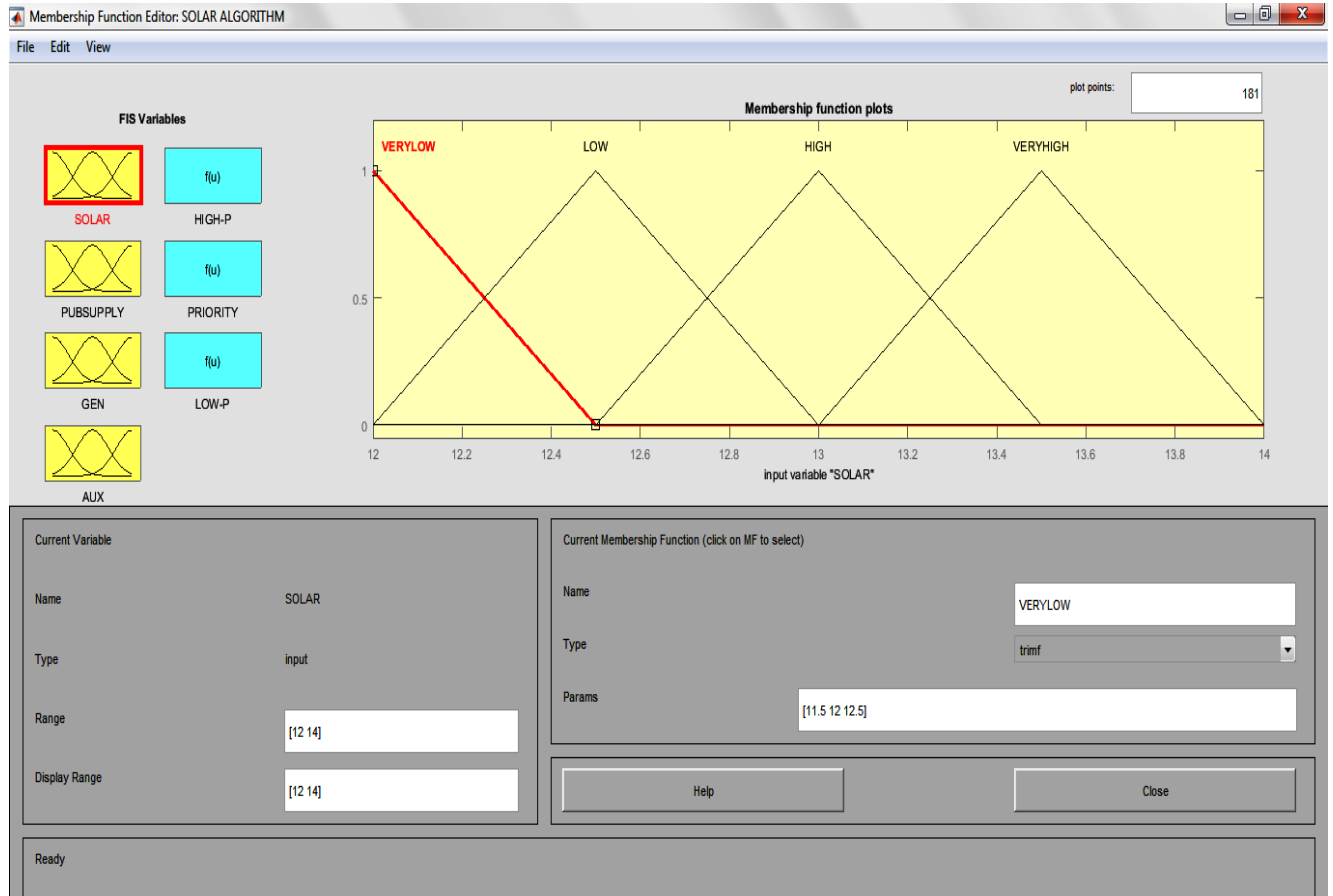

Figure 3.20: Fuzzification of the Solar Plant Using the Battery SoC

Figure 3.21 also shows the fuzzification of the Public supply input source. It has only two states, LOW or HIGH, since it is either available or not available. The accepted voltage is taken as HIGH, that is, available, while anything other than the range is seen as LOW that is not available.

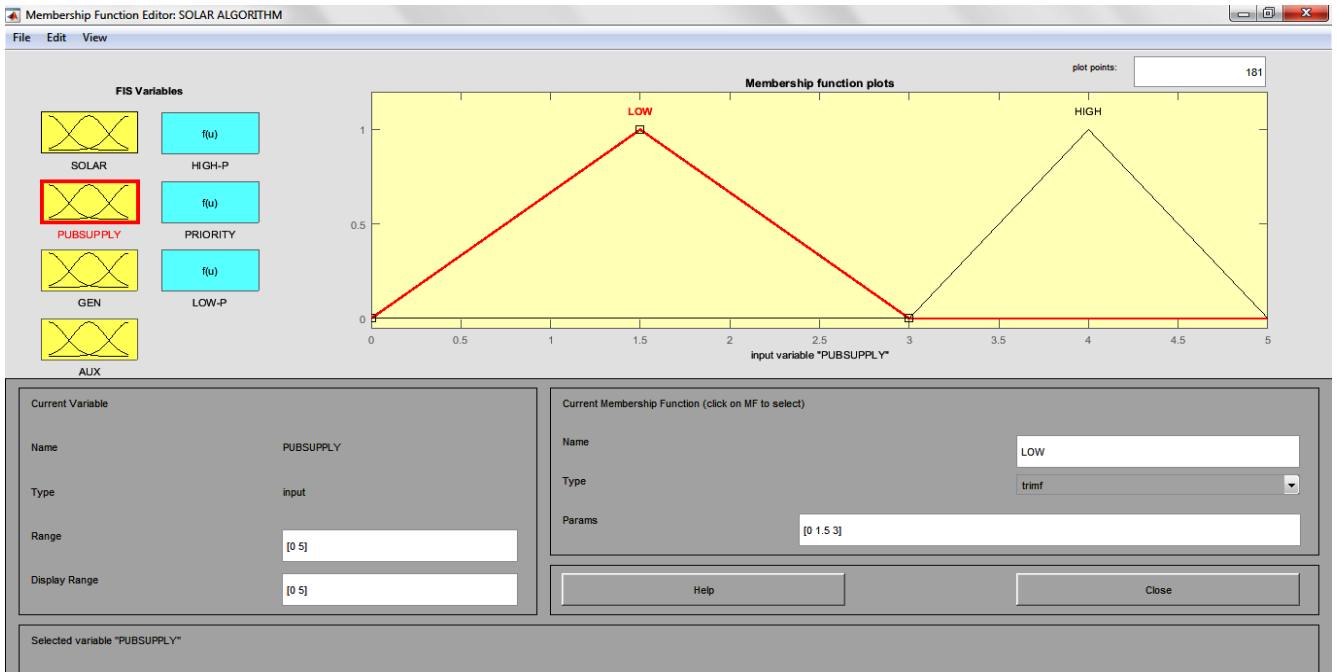

Figure 3.21: Fuzzification of the PUB.SUPPLY

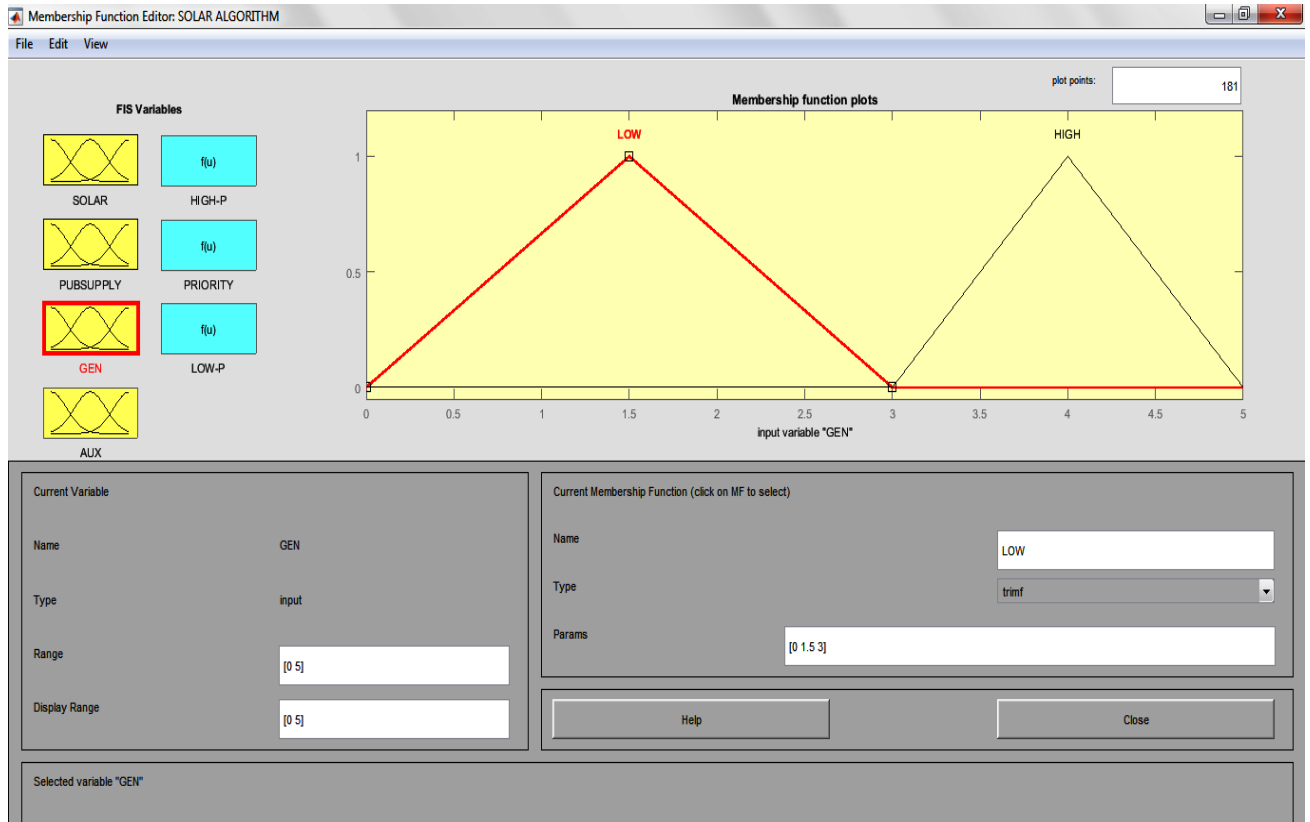

Figure 3.22: Fuzzification of the GEN input

In the same way, the fuzzification of the GEN input is also shown in figure 3.22 above; the two states available once again are LOW or HIGH, since the GEN can either be ON or OFF.

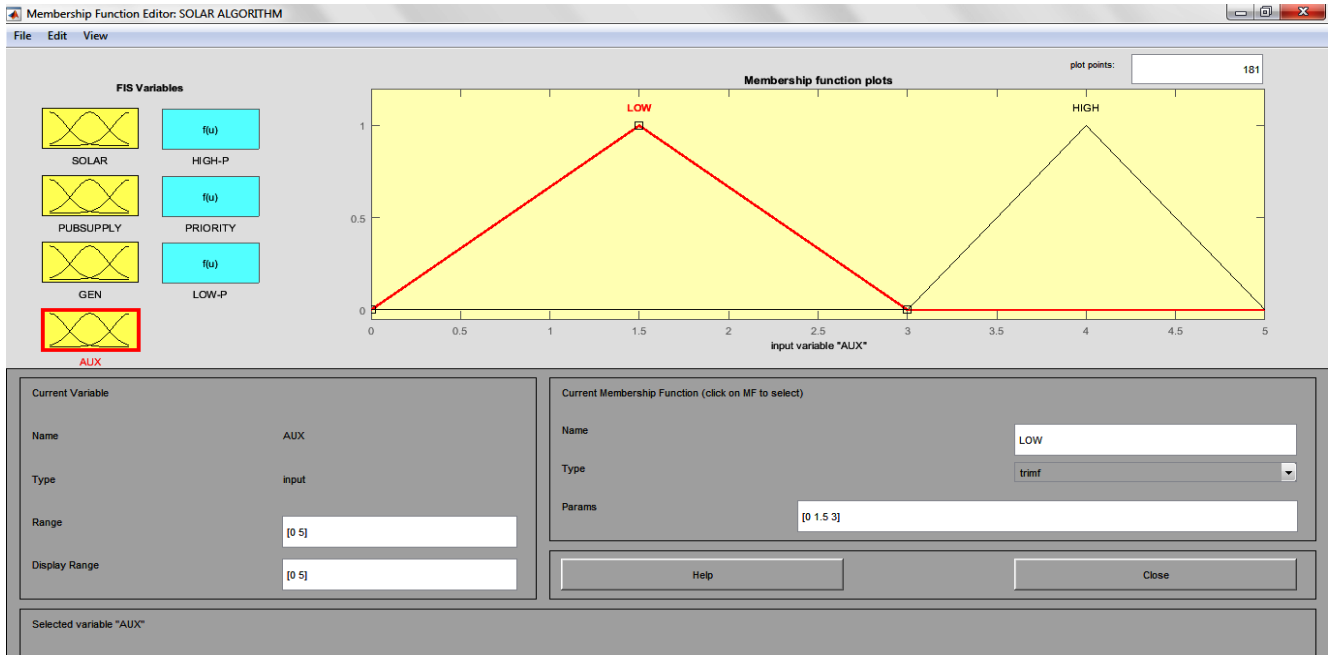

Figure 3.23: Fuzzification of the AUX input

Also, figure 3.23, shows the fuzzification of the Auxiliary energy input (AUX.) it has two fuzzy state also because it is either available (HIGH) or unavailable (LOW).

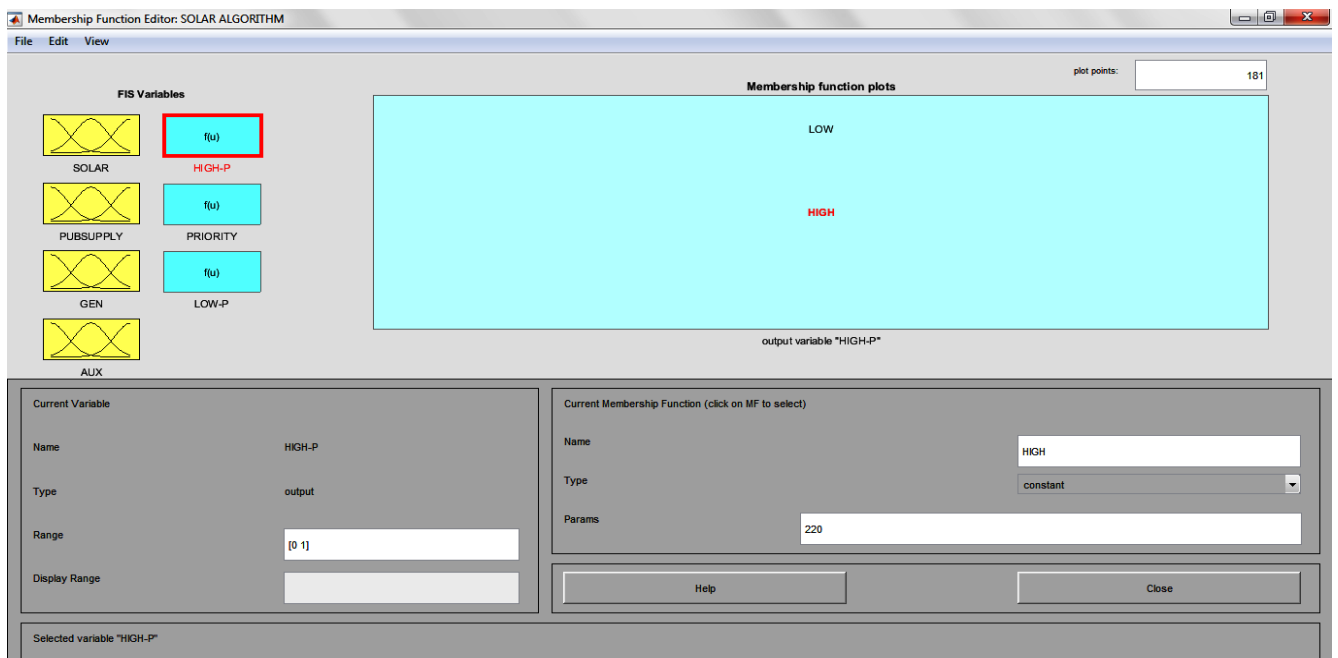

Figure 3.24: Defuzzification of the High Priority (HIGH-P) output

The results of the fuzzy logic algorithm will determine which of the output or outputs are supplied at any set time (t). Figures 3.24, 3.25 and 3.26 show the defuzzification of the

high priority (HIGH-P), PRIORITY and the LOW-P outputs respectively to give the desired outputs.

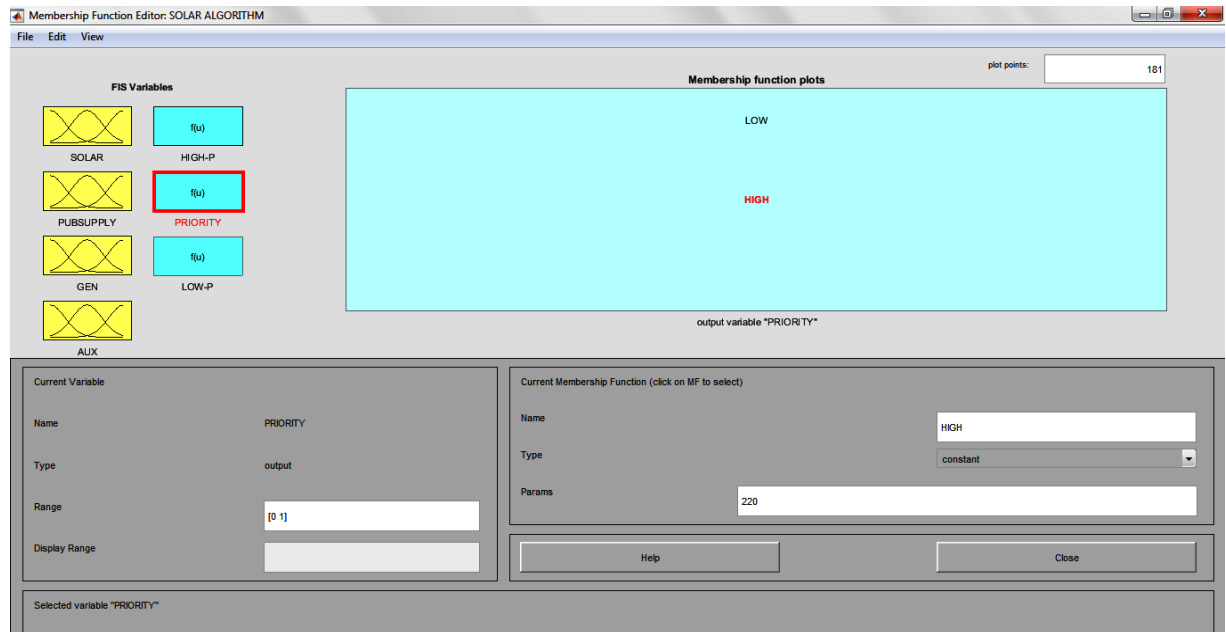

Figure 3.25: Defuzzification of the Priority (PRIORITY) output

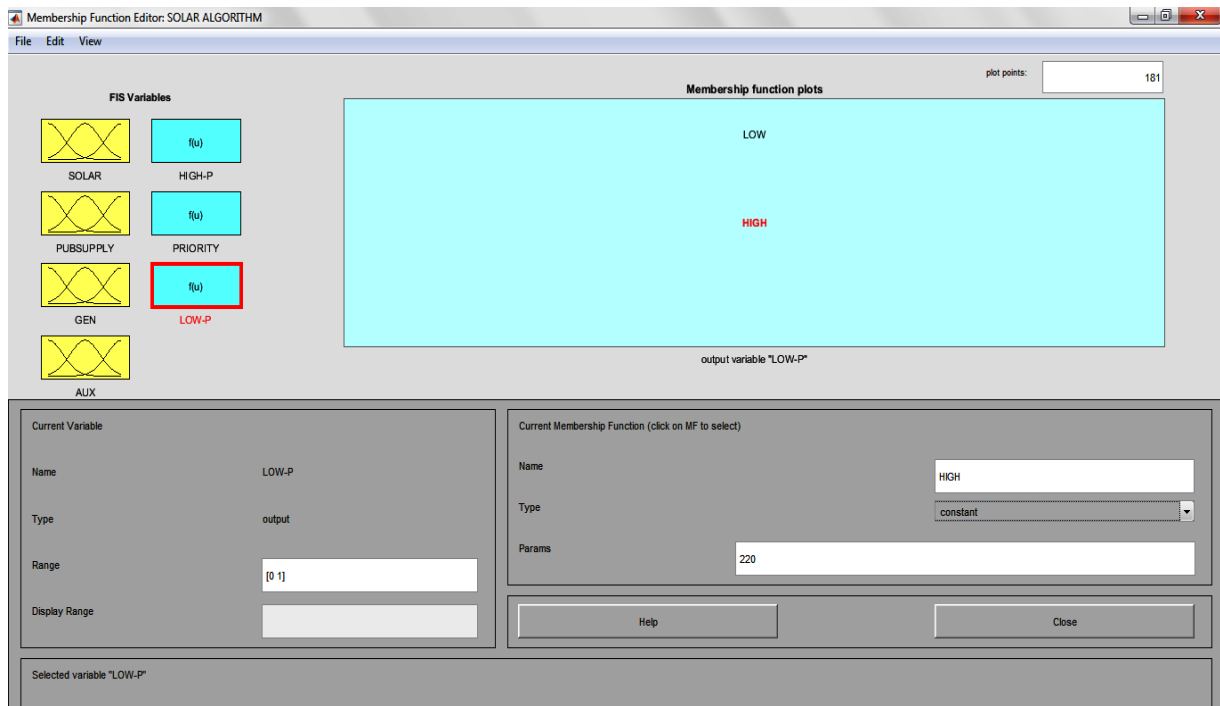

Figure 3.26: Defuzzification of the Less Priority output

The model of fuzzy logic model of LIAs is shown in figure 3.27 below. It clearly shows all the energy inputs to the model. The primary power source for the microgrid is solar energy, however as we draw from the solar plant the LIA monitors the SoC of the BESS to know

when to call up the other energy input sources. The batteries can either be recharged by the solar panels, or through the converter via then utility grid or the diesel GEN.

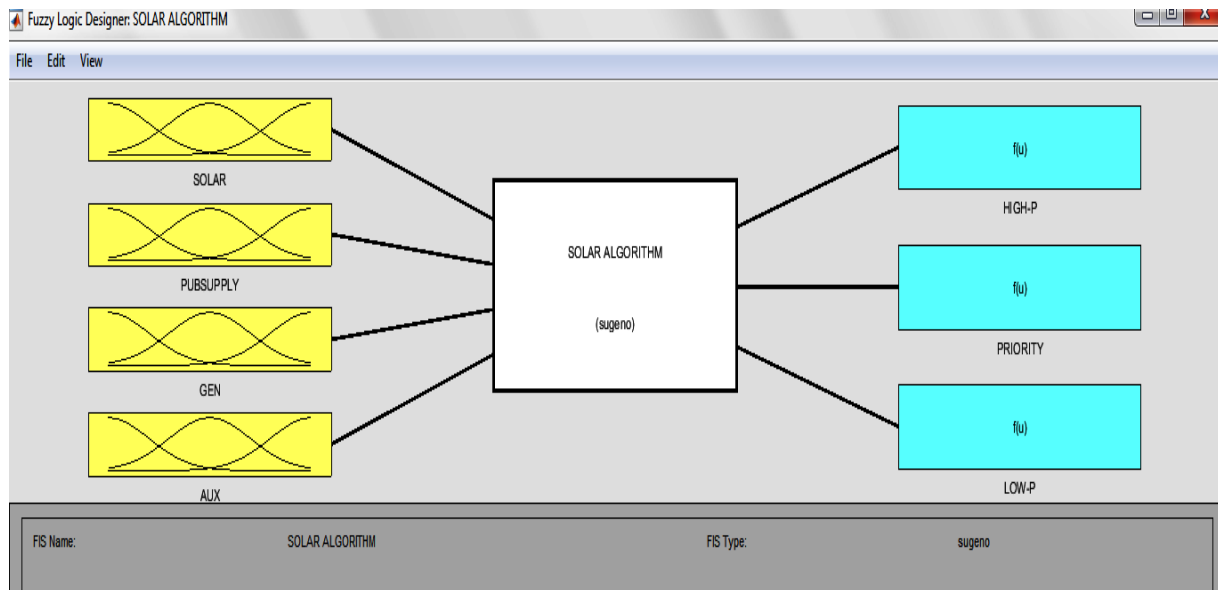

Figure 3.27 Fuzzy Logic Model for the L.I.A

The power input sources available to the sub-grids are processed using the fuzzy logic rules provided at the rule editor. This LIA model used twenty nine (29) rules to process its outputs.

Figure 3.28 shows the rules in the rule editor.

```

Rule Editor: SOLAR_ALGORITHM
File Edit View Options

1. If (SOLAR is VERYHIGH) then (HIGH-P is HIGH)(PRIORITY is HIGH)(LOW-P is HIGH) (1)
2. If (SOLAR is HIGH) and (AUX is HIGH) then (HIGH-P is HIGH)(PRIORITY is HIGH)(LOW-P is HIGH) (1)
3. If (SOLAR is HIGH) and (PUBSUPPLY is HIGH) and (AUX is LOW) then (HIGH-P is HIGH)(PRIORITY is HIGH)(LOW-P is HIGH) (1)
4. If (SOLAR is HIGH) and (PUBSUPPLY is LOW) and (AUX is LOW) then (HIGH-P is HIGH)(PRIORITY is HIGH)(LOW-P is LOW) (1)
5. If (SOLAR is LOW) and (PUBSUPPLY is LOW) and (AUX is LOW) then (HIGH-P is HIGH)(PRIORITY is LOW)(LOW-P is LOW) (1)
6. If (SOLAR is LOW) and (PUBSUPPLY is LOW) and (AUX is HIGH) then (HIGH-P is HIGH)(PRIORITY is LOW)(LOW-P is LOW) (1)
7. If (SOLAR is LOW) and (PUBSUPPLY is HIGH) then (HIGH-P is HIGH)(PRIORITY is HIGH)(LOW-P is HIGH) (1)
8. If (SOLAR is VERYLOW) and (PUBSUPPLY is LOW) and (GEN is LOW) and (AUX is HIGH) then (HIGH-P is HIGH)(PRIORITY is LOW)(LOW-P is LOW) (1)
9. If (SOLAR is VERYLOW) and (PUBSUPPLY is LOW) and (GEN is HIGH) and (AUX is LOW) then (HIGH-P is HIGH)(PRIORITY is HIGH)(LOW-P is HIGH) (1)
10. If (SOLAR is VERYLOW) and (PUBSUPPLY is LOW) and (GEN is LOW) and (AUX is LOW) then (HIGH-P is LOW)(PRIORITY is LOW)(LOW-P is LOW) (1)
11. If (SOLAR is VERYLOW) and (PUBSUPPLY is LOW) and (GEN is LOW) and (AUX is HIGH) then (HIGH-P is HIGH)(PRIORITY is LOW)(LOW-P is LOW) (1)
12. If (SOLAR is VERYLOW) and (PUBSUPPLY is LOW) and (GEN is HIGH) and (AUX is LOW) then (HIGH-P is HIGH)(PRIORITY is HIGH)(LOW-P is HIGH) (1)
13. If (SOLAR is VERYLOW) and (PUBSUPPLY is HIGH) and (GEN is LOW) and (AUX is LOW) then (HIGH-P is HIGH)(PRIORITY is HIGH)(LOW-P is HIGH) (1)
14. If (SOLAR is VERYLOW) and (PUBSUPPLY is HIGH) and (GEN is HIGH) and (AUX is HIGH) then (HIGH-P is HIGH)(PRIORITY is HIGH)(LOW-P is HIGH) (1)
15. If (SOLAR is LOW) and (PUBSUPPLY is LOW) and (GEN is LOW) and (AUX is LOW) then (HIGH-P is HIGH)(PRIORITY is LOW)(LOW-P is LOW) (1)
16. If (SOLAR is LOW) and (PUBSUPPLY is LOW) and (GEN is LOW) and (AUX is HIGH) then (HIGH-P is HIGH)(PRIORITY is HIGH)(LOW-P is LOW) (1)
17. If (SOLAR is LOW) and (PUBSUPPLY is LOW) and (GEN is HIGH) and (AUX is LOW) then (HIGH-P is HIGH)(PRIORITY is HIGH)(LOW-P is HIGH) (1)

```

Figure 3.28 Rules for model control in the Rule editor

3.9.3 SIMULINK Implementation of LIA Fuzzy Logic Model

The local intelligent agent (LIA) was implemented in SIMULINK to test the result fuzzy logic Algorithm developed for the LIAs. Figure 3.29 shows the implementation. It comprises of four constant blocks, a 4-input multiplexer (MUX), a Fuzzy logic Controller with rule

viewer, 3- output de-multiplexer (DEMUX) and three displays .The constant blocks are used for inputting the state of each energy input source available to the sub-grid; for the purpose of simulation, the MUX, multiplexes the all energy input sources into the fuzzy controller, the fuzzy controller takes decisions based on a set of twenty nine (29) rules and its output is de-multiplexed to the three load categories being managed within the sub-grid, which are the high priority, priority and less priority loads.

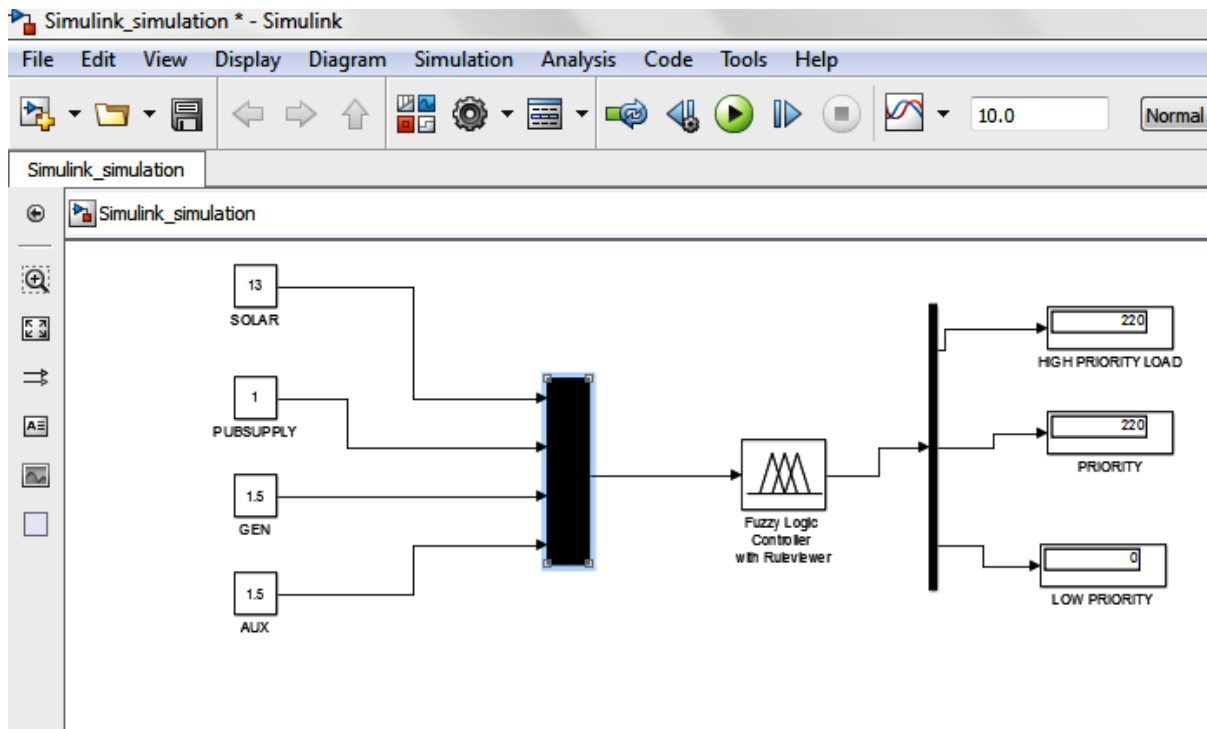

Figure 3.29: MATLAB SIMULINK implementation of the LIA

3.10 Validation of the Model

The developed model was validated by adjusting its input parameter to model an energy scheduling model for the ongoing 2MVA solar-diesel mini-grid in Nnamdi Azikiwe University. The plant is made up of four power input sources, which are, the PV inverters (grid tie inverters), the Battery inverters, the diesel generators and the utility grid. The description of the plant is as shown in figure 3.30 below, for ease of energy scheduling. The model for the smart energy management system already developed was adjusted to handle the energy scheduling in the plant site for the mini-grid. The plant is designed to continuously maintain an out power of 2MVA, by adding or removing the available power input resources. Also the plant design specifies that 40% of the install capacity must be reserved in the BESS

for the night loads. Figure 3.31 also shows the adjusted model of the energy management system used for energy scheduling for the ongoing Nnamdi Azikiwe University Mini Grid. While figure 3.32 shows the fuzzy rules required for proper energy scheduling.

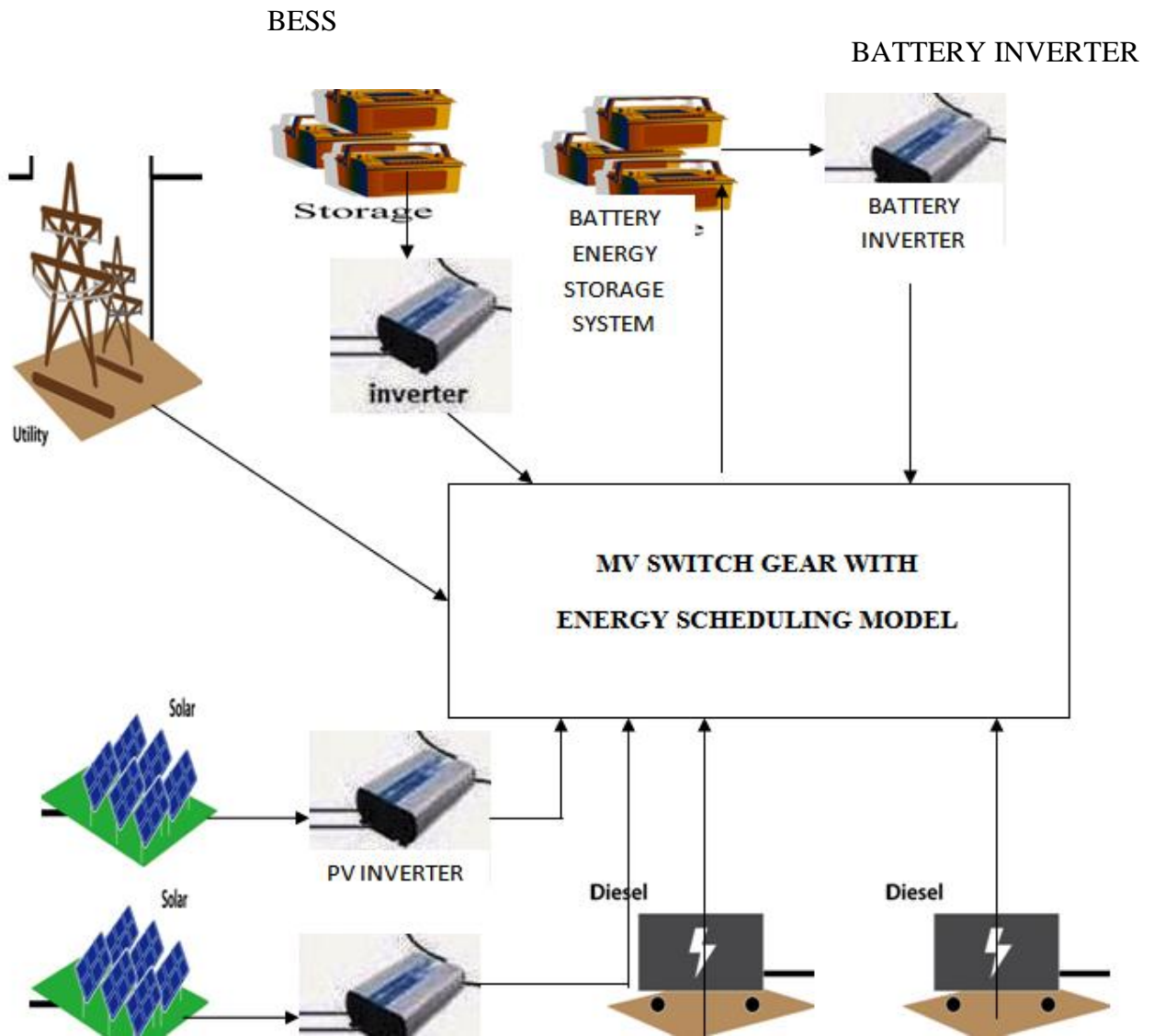

Figure 3.30 : High Level Description of the Ongoing Mini-grid at NAU Awka

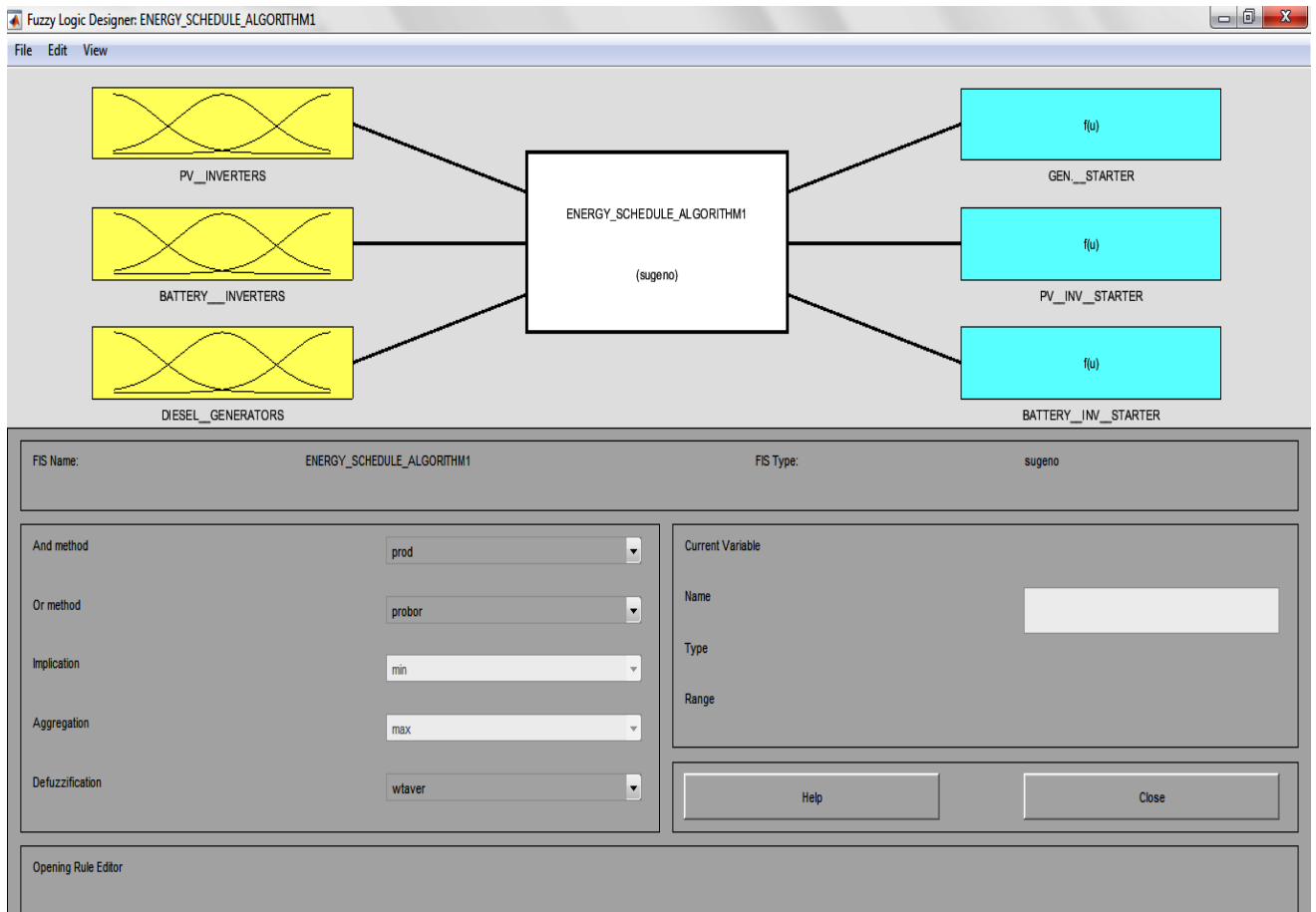

Figure 3.31: Energy Scheduling Model for the Ongoing Nnamdi Azikiwe Mini-Grid.

```

Rule Editor: ENERGY_SCHEDULE_ALGORITHM1
File Edit View Options

1. If (PV__INVERTERS is VERYHIGH) then (GEN__STARTER is LOW)(BATTERY__INV__STARTER is LOW) (1)
2. If (PV__INVERTERS is HIGH) then (GEN__STARTER is HIGH)(BATTERY__INV__STARTER is LOW) (1)
3. If (PV__INVERTERS is LOW) then (GEN__STARTER is HIGH)(BATTERY__INV__STARTER is LOW) (1)
4. If (PV__INVERTERS is VERYLOW) then (GEN__STARTER is HIGH)(PV__INV__STARTER is LOW)(BATTERY__INV__STARTER is HIGH) (1)
5. If (BATTERY__INVERTERS is VERYHIGH) then (GEN__STARTER is LOW)(PV__INV__STARTER is LOW) (1)
6. If (BATTERY__INVERTERS is HIGH) then (GEN__STARTER is HIGH)(PV__INV__STARTER is LOW) (1)
7. If (BATTERY__INVERTERS is LOW) then (GEN__STARTER is HIGH)(PV__INV__STARTER is HIGH) (1)
8. If (BATTERY__INVERTERS is VERYLOW) then (GEN__STARTER is HIGH)(PV__INV__STARTER is HIGH)(BATTERY__INV__STARTER is LOW) (1)
9. If (DIESEL__GENERATORS is VERYHIGH) then (PV__INV__STARTER is LOW)(BATTERY__INV__STARTER is LOW) (1)
10. If (DIESEL__GENERATORS is HIGH) then (PV__INV__STARTER is HIGH)(BATTERY__INV__STARTER is LOW) (1)
11. If (DIESEL__GENERATORS is LOW) then (PV__INV__STARTER is HIGH)(BATTERY__INV__STARTER is LOW) (1)
12. If (DIESEL__GENERATORS is VERYLOW) then (GEN__STARTER is LOW)(PV__INV__STARTER is HIGH)(BATTERY__INV__STARTER is HIGH) (1)

```

Figure 3.32: Rules for Energy Scheduling of the developed model for Ongoing Nnamdi Azikiwe Mini-Grid

The model monitors the states of the three major input power sources, that is the PV inverters, the battery inverters and the Diesel Generators. Four states are defined for the PV and battery inverters, which are; VERYLOW, LOW, HIGH AND VERYHIGH. VERYLOW STATE implies that it has to be shut down and all the diesel generators started and Battery inverters, LOW state implies that the model must start all the of the diesel generator to support the PV inverter, HIGH implies that one of the start one of the diesel generator to support the PV inverters while VERYHIGH implies that the PV inverter can provide the needed energy within the mini-grid.

3.11 Summary of Methodology

The resulting model is not stereotyped to this application; it can also be applied in some other instances of the grid technology, where energy management or intelligent control is required as shown in figure 3.32, where it was applied in energy scheduling. It can be adopted for energy scheduling for microgrid will many power input source with varying capacity. The model works very well for any instance of energy management within the micro grid. It also finds a good application in any microgrid setup where many input sources are available and needs to be properly managed to supply the setup.

Proper simulation and testing was carried out on the modelled LIA above to decipher its responses and decision at different states of the energy inputs sources to the sub-grids. Their results and discussion were presented in the next chapter.

CHAPTER FOUR

RESULTS AND DISCUSSIONS

4.1 Presentation and Discussion of Results

The LIAs which are multi-function intelligent agents responsible for energy management within each sub-grid of the Microgrid, which were modelled with fuzzy logic using the Fuzzy Inference System (FIS), were now implemented using MatLab Simulink. A fuzzy logic controller in Simulink was used to simulate the modelled algorithm using test signals and the results were obtained. These results depict the real time performance of the LIA. Ten different possible test scenarios were used to test the LIA and the results are as shown in the figures 4.1 to 4.31. In addition, during the development of the fuzzy logic model for the system, certain decisions were taken for easy implementation of the model. These decisions were taken for the four input source to the sub-grids.

For the solar plant, four different possible states were adopted, represented by the following fuzzy logic linguistic variables; VERYLOW, LOW, HIGH and VERYHIGH. The SoC of the BESS was adopted to represent these variables, since battery inverters were used for the solar plant design. Thus, the average battery voltage range (12 to 13.5V) was used. Therefore the signals indicating VERYLOW = 12.1V, LOW = 12.5V, HIGH = 13.0V, VERYHIGH = 13.5V. These signals were given as input to the Fuzzy logic controller, in conjunction with the signals from the other three inputs and the results are shown in the figure hereby presented.

In the same way, the other three power inputs to the sub-grids, the utility grid supply denoted by (PUBSUPPLY), diesel generator denoted by (GEN) and the Auxiliary power from neighbouring sub-grid, denoted by (AUX.) have only two possible states, LOW or HIGH, since they are either available or not, LOW means they are not available, while HIGH means that they are available. The signal input representing LOW = 1 to 1.5V, while HIGH = 4.5 to 4.9.

4.2 Discussion of Results

Ten possible scenarios have been used to test the modelled energy management system and the results of the system response are presented in figure 4.1 to figure 4.31. The rule view and the graphical outputs of the system were also presented for clearer understanding of the system response. The ten scenarios are;

- Scenario 1: Solar is VERY HIGH with all other inputs HIGH
- Scenario 2: Solar is VERYLOW with all the other inputs LOW

- Scenario 3: Solar is VERY HIGH with all other inputs LOW
- Scenario 4: Solar is VERY LOW, PUBSUPPLY HIGH with all other inputs LOW
- Scenario 5: Solar is VERY LOW, AUX. HIGH with all other inputs LOW
- Scenario 6: Solar is VERY LOW, GEN. HIGH with all other inputs LOW
- Scenario 7: Solar is LOW with all other inputs LOW
- Scenario 8: Solar is LOW, AUX. HIGH, with all other inputs LOW
- Scenario 9: Solar is HIGH with all other inputs LOW
- Scenario 10: Solar is HIGH, AUX. HIGH with all other inputs LOW

4.2.1 Scenario 1: Results when Solar is VERY HIGH with all other inputs HIGH

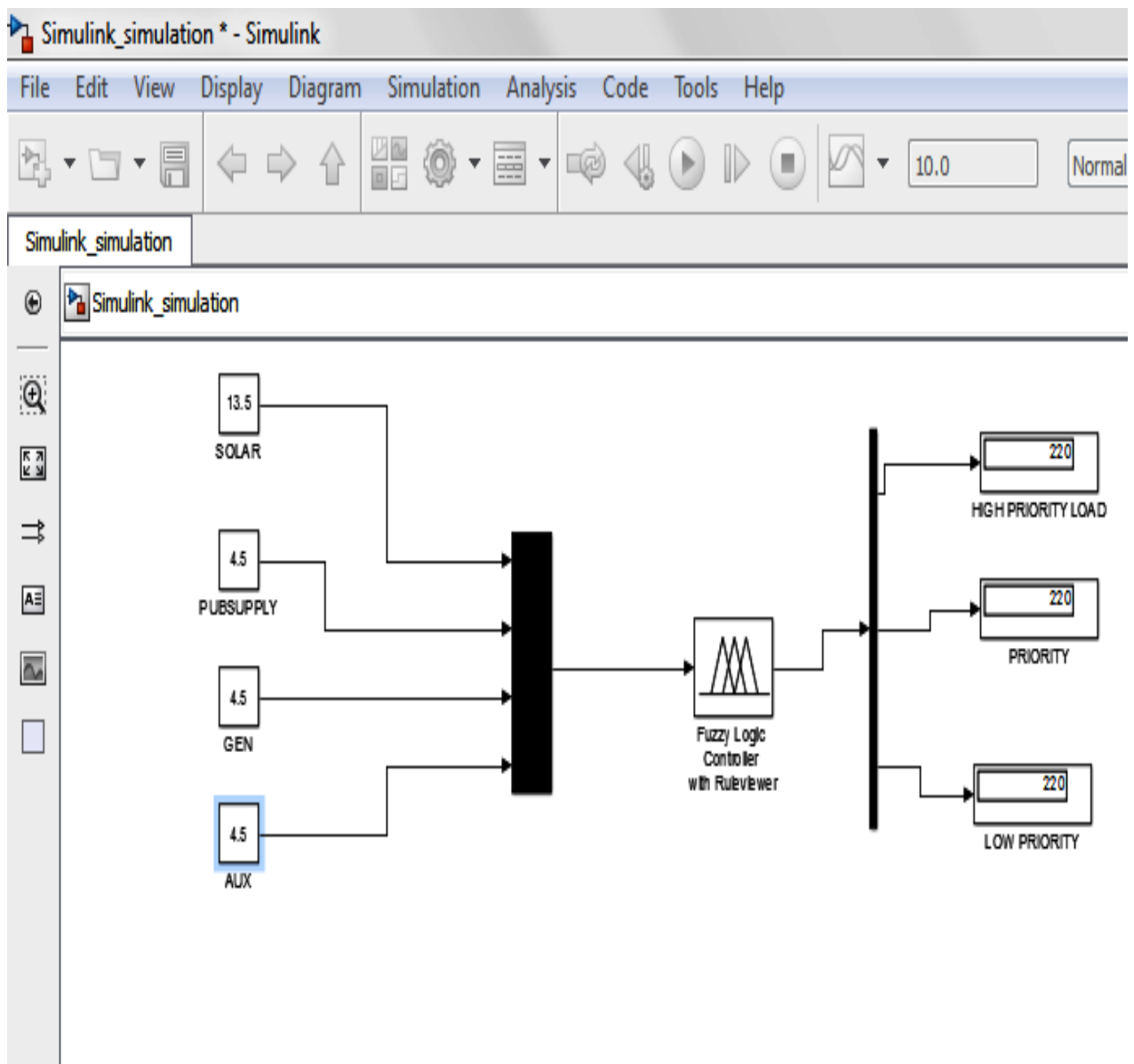

Figure 4.1 Solar input VERYHIGH, with all the other inputs HIGH

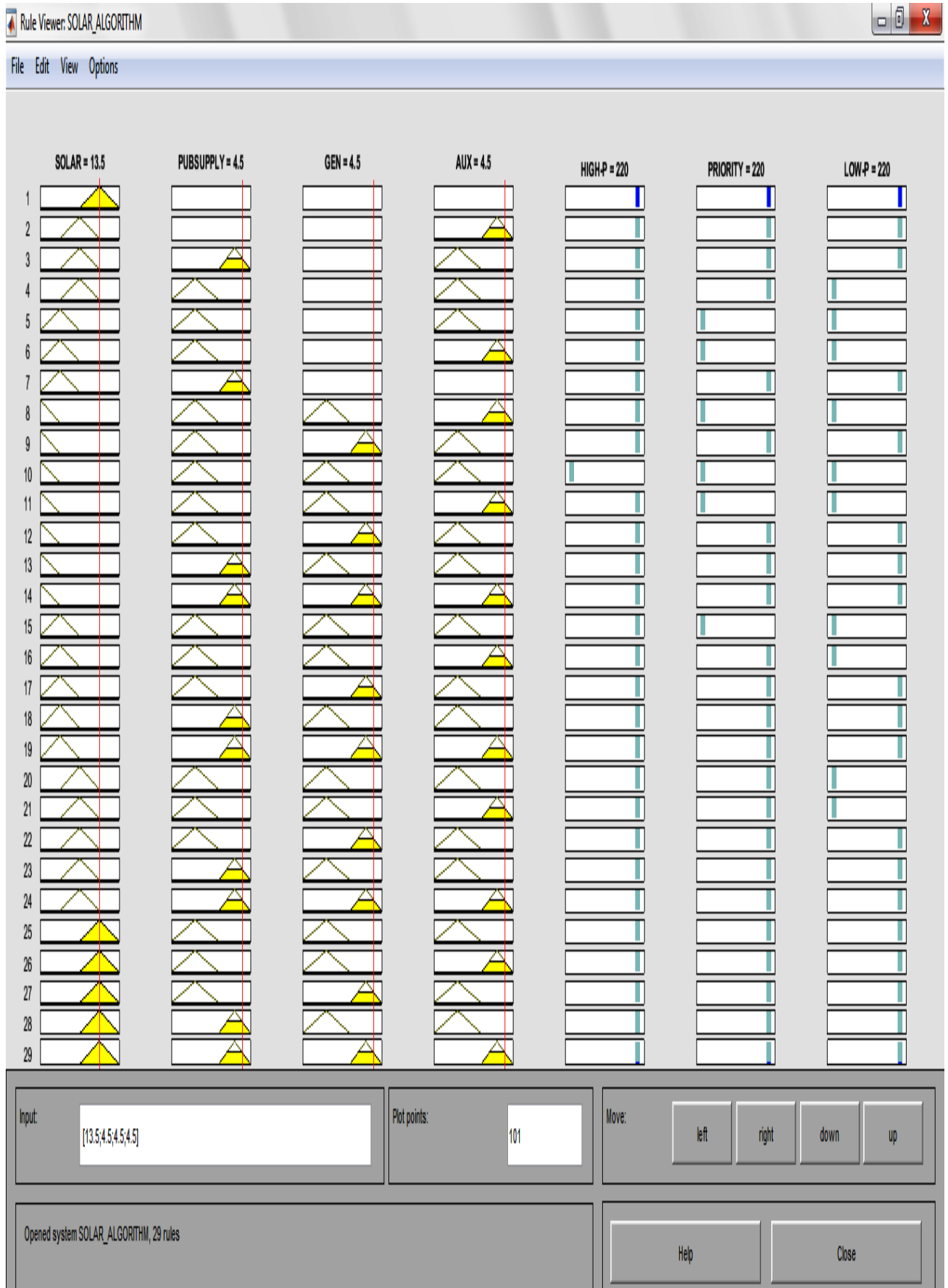

Figure 4.2: Rule Viewer for figure 4.1

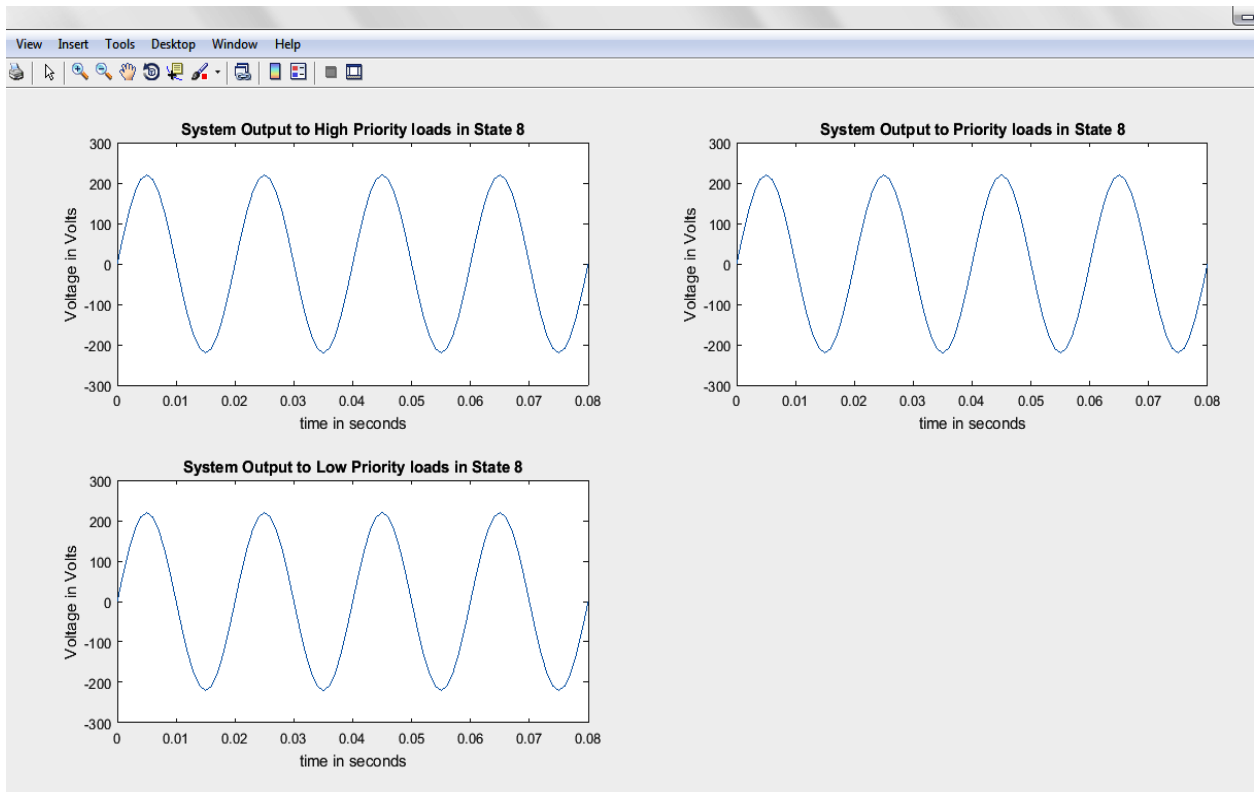

Figure 4.3: Graphical View of sub-grid outputs for 4.1

4.2.1.1 Discussion of Results for Scenario 1

From figure 4.1, when solar is at a VERYHIGH state and all the other power sources are available, the three categories of loads within the sub-grid, that is, the high priority (hpl), the priority (pl) and the less priority (lpl) loads are all supplied. However, the energy managements system chooses the cheapest at that time to run the sub-grid, which is solar energy. The display, the rule view and the load output graphs in figure 4.1, 4.2 and 4.3 respectively clearly shows all the load categories are fully supplied.

4.2.2 Scenario 2: Results when Solar is VERYLOW with all other inputs LOW

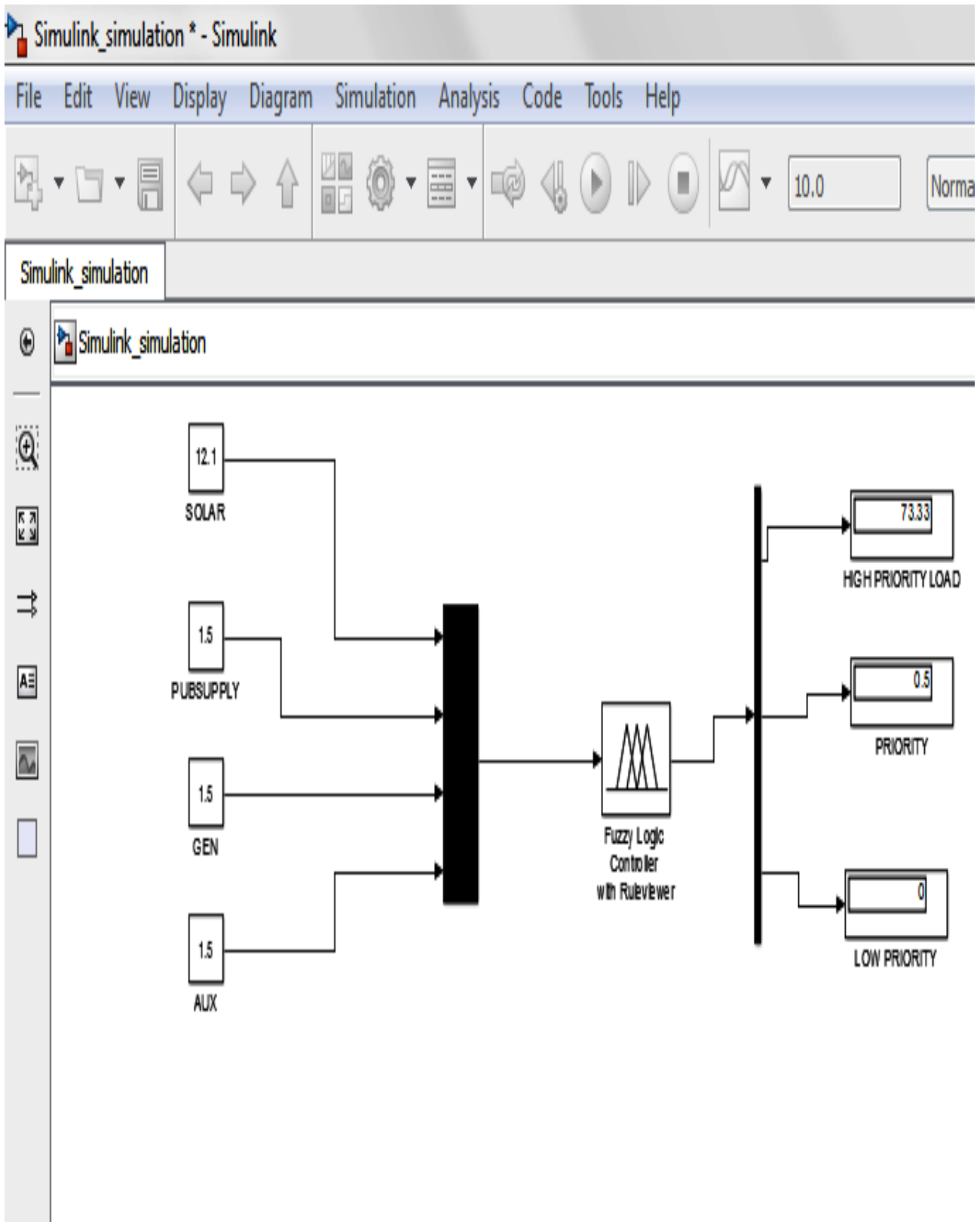

Figure 4.4: Solar input VERYLOW with all the other inputs LOW

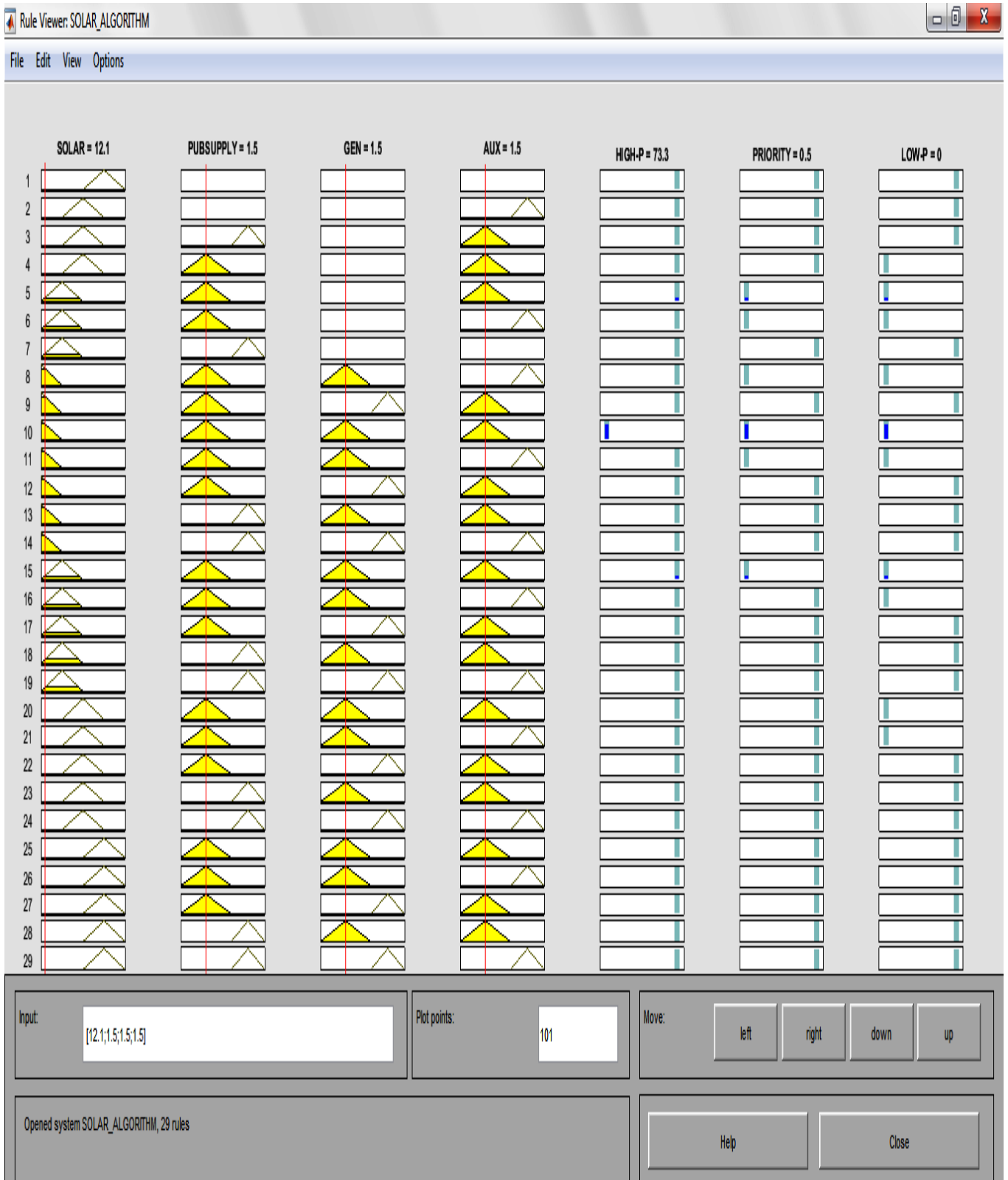

Figure 4.5: Rule View for Figure 4.4 scenario

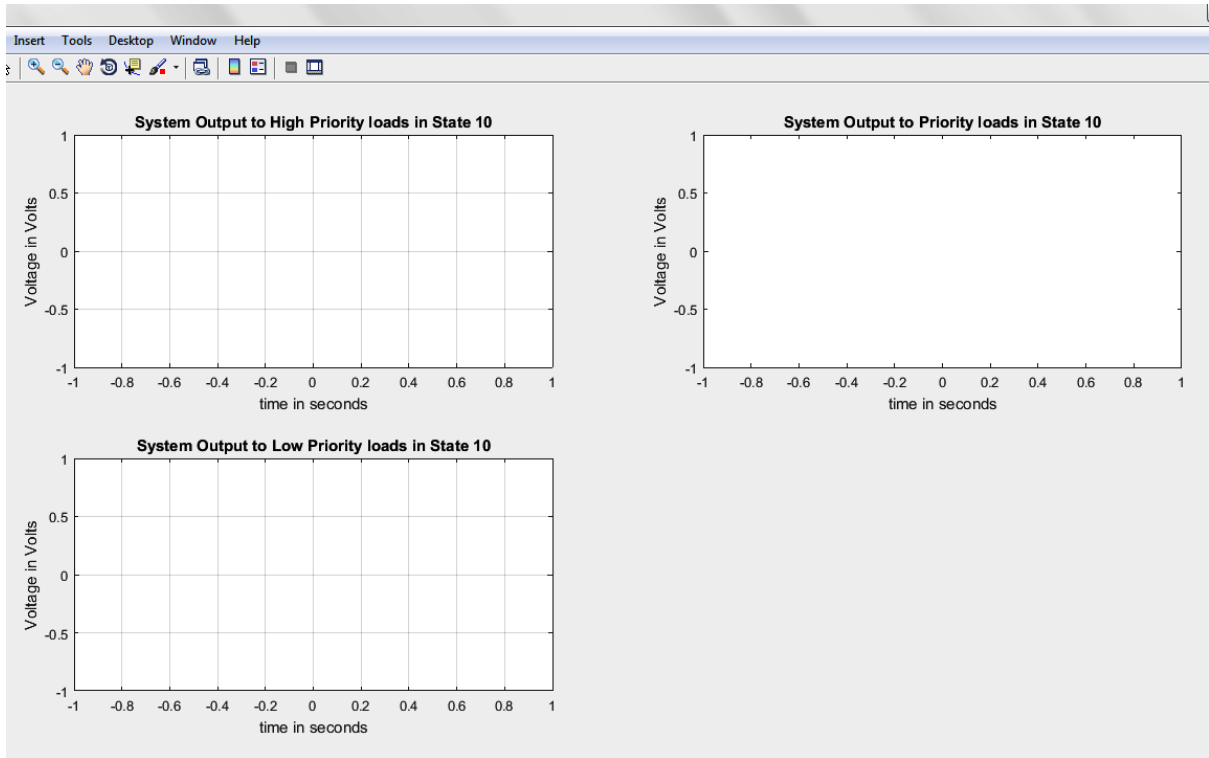

Figure 4.6: Graphical View of sub-grid outputs for fig4.4

4.2.2.1 Discussion of Results for Scenario 2

Figure 4.4 above shows the system's response when solar is VERYLOW and all the other power inputs are not available. From the display, rule view and the a.c voltage output graphs of the load categories in figures 4.4, 4.5 and 4.6 respectively, none of the electrical load categories are supplied. This energy management strategy is very important in order to protect the battery health of the solar plant. This implies that the solar plant only supplies when its status is at least LOW state. This scenario however, is rear, and must not be allowed but if it ever occurs all the outputs will be shutdown.

4.2.3 Scenario 3: Results when Solar is VERYHIGH with all other inputs LOW

In this scenario, the solar plant is at VERYHIGH state, while all the other inputs are not available, i.e. are at LOW state. This particular scenario is the cheapest option for providing electrical energy at the sub-grids, since it depends on the major renewable source used for this design; solar energy. The results of this scenario is presented in figures 4.7 to 4.9.

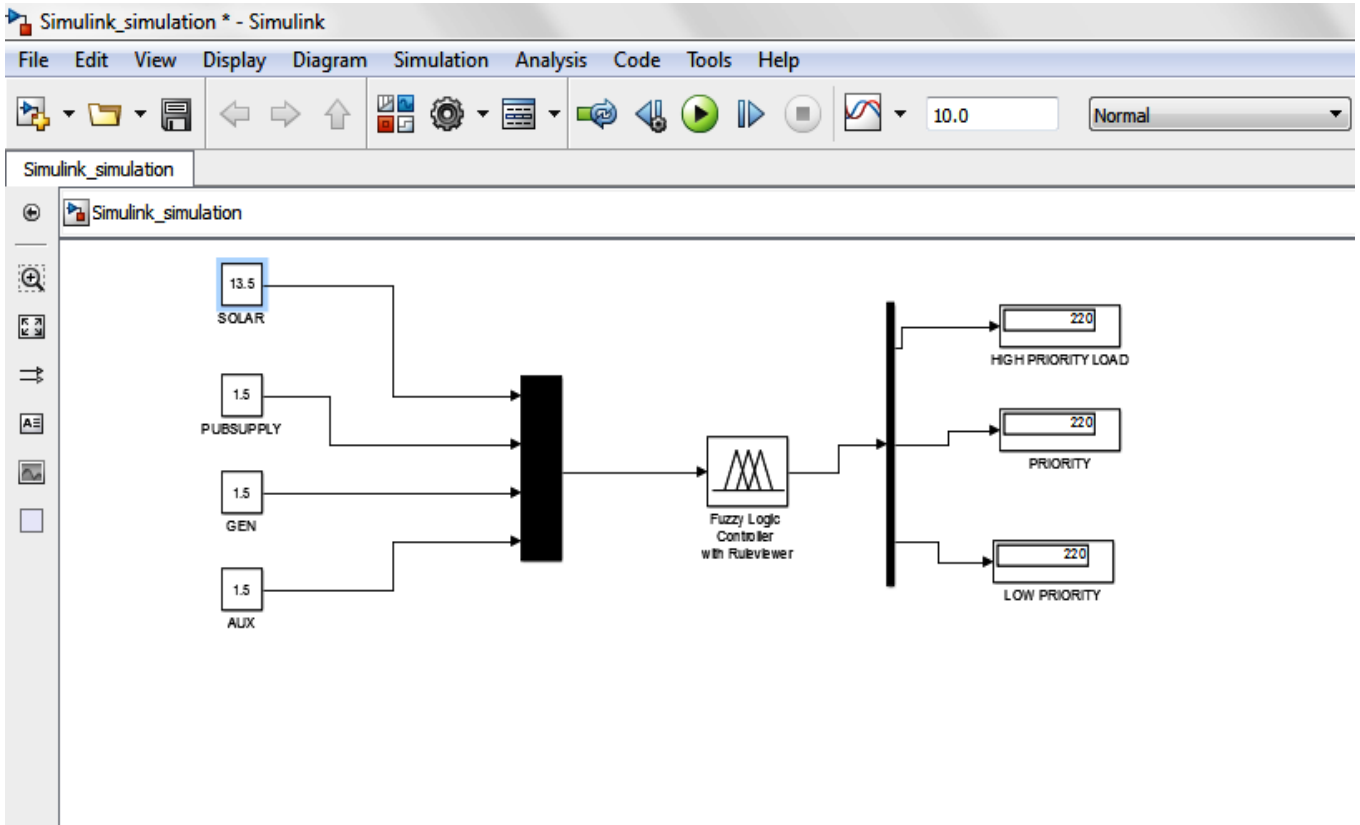

Figure 4.7: Solar input VERYHIGH with all the other inputs LOW

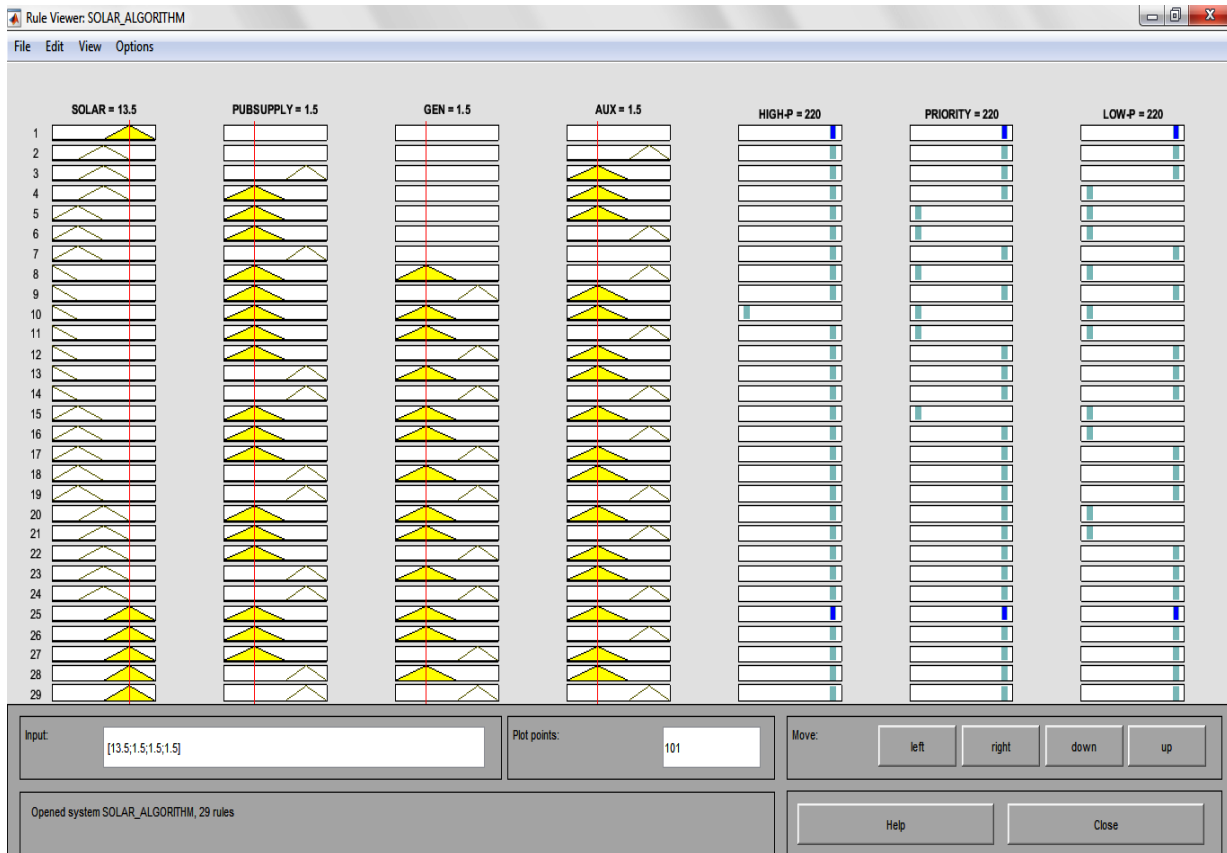

Figure 4.8: Rule View for Figure 4.7 scenario

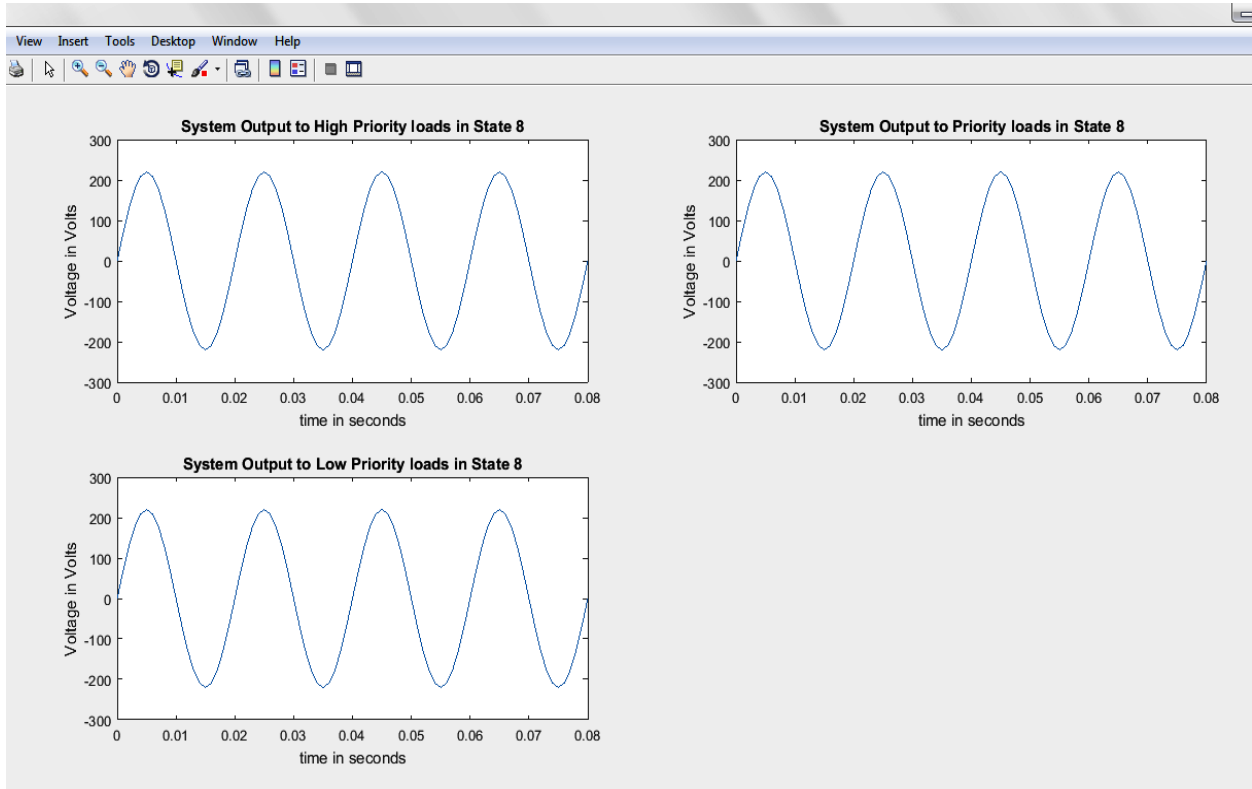

Figure 4.9: Graphical View of sub-grid outputs for figure 4.7

4.2.3.1 Discussion of Results for Scenario 3

This scenario as shown in figure 4.7 clearly shows that the solar plant has enough energy to run the entire microgrid. Thus all the load categories are supplied as indicated in the display, the rule view and the output load graph in figures 4.7, 4.8 and 4.9. This scenario is the best to run the microgrid as it is the cheapest. The solar plant state will often be at a VERYHIGH state, since solar energy is readily available most of the time.

4.2.4 Scenario 4: Results when Solar is VERYLOW, PUBSUPPLY HIGH with all other inputs LOW

In this scenario the solar plant is at VERYLOW state, PUBSUPPLY is available, and all the other options are not available. The Result of the simulation of this scenario are presented in figures 4.10 to 4.12.

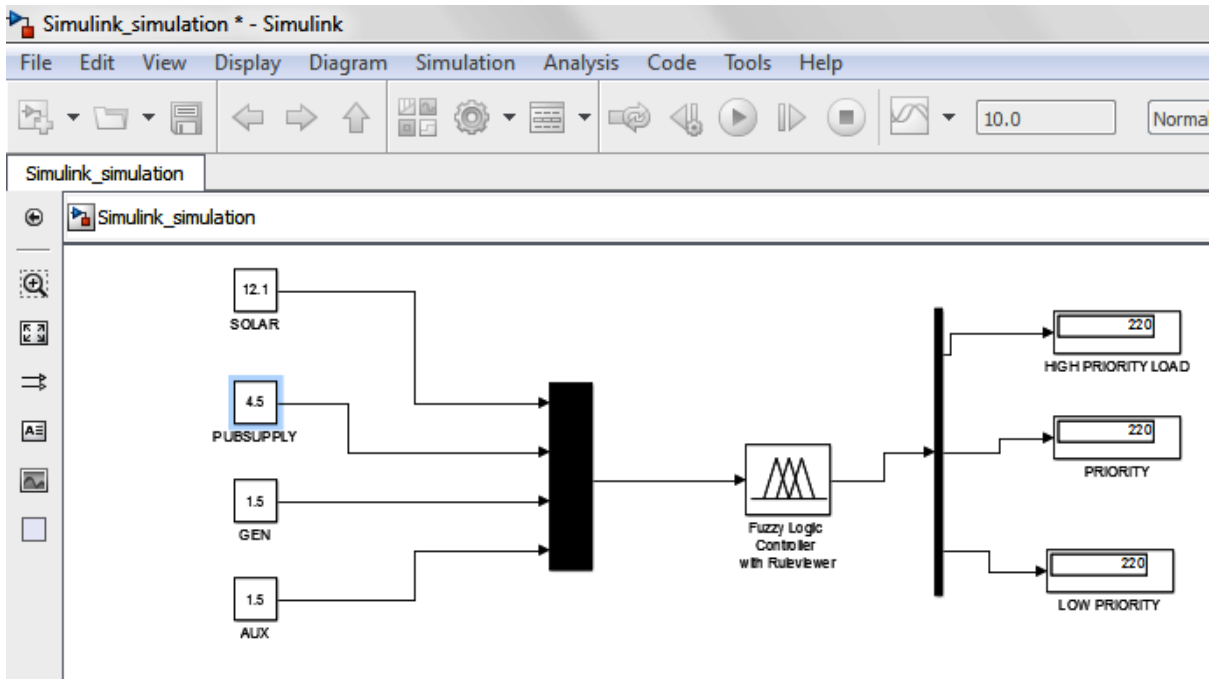

Figure 4.10: Solar input VERYLOW, PUBSUPPLY HIGH with the other inputs LOW

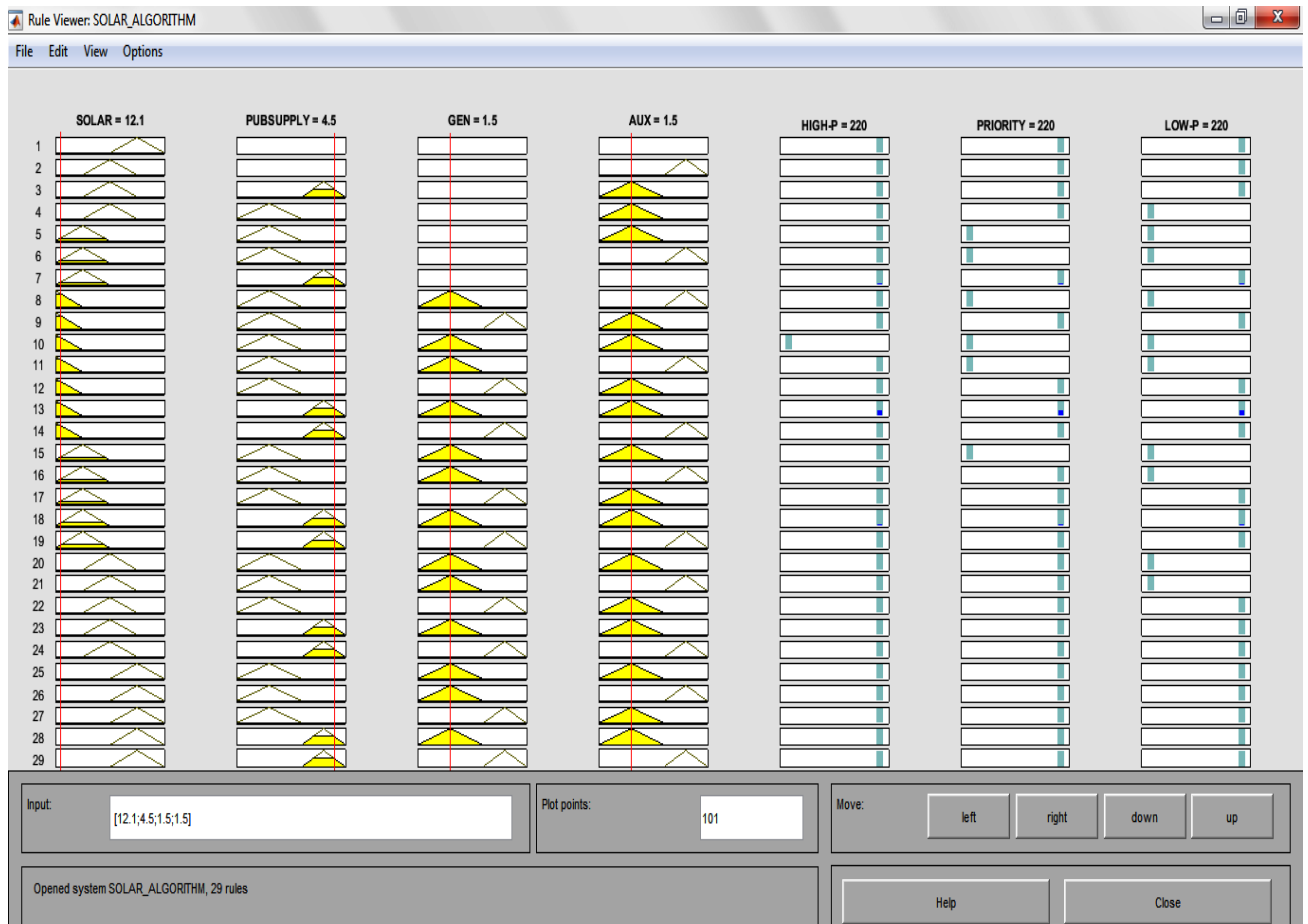

Figure 4.11: Rule View for Figure 4.10 above

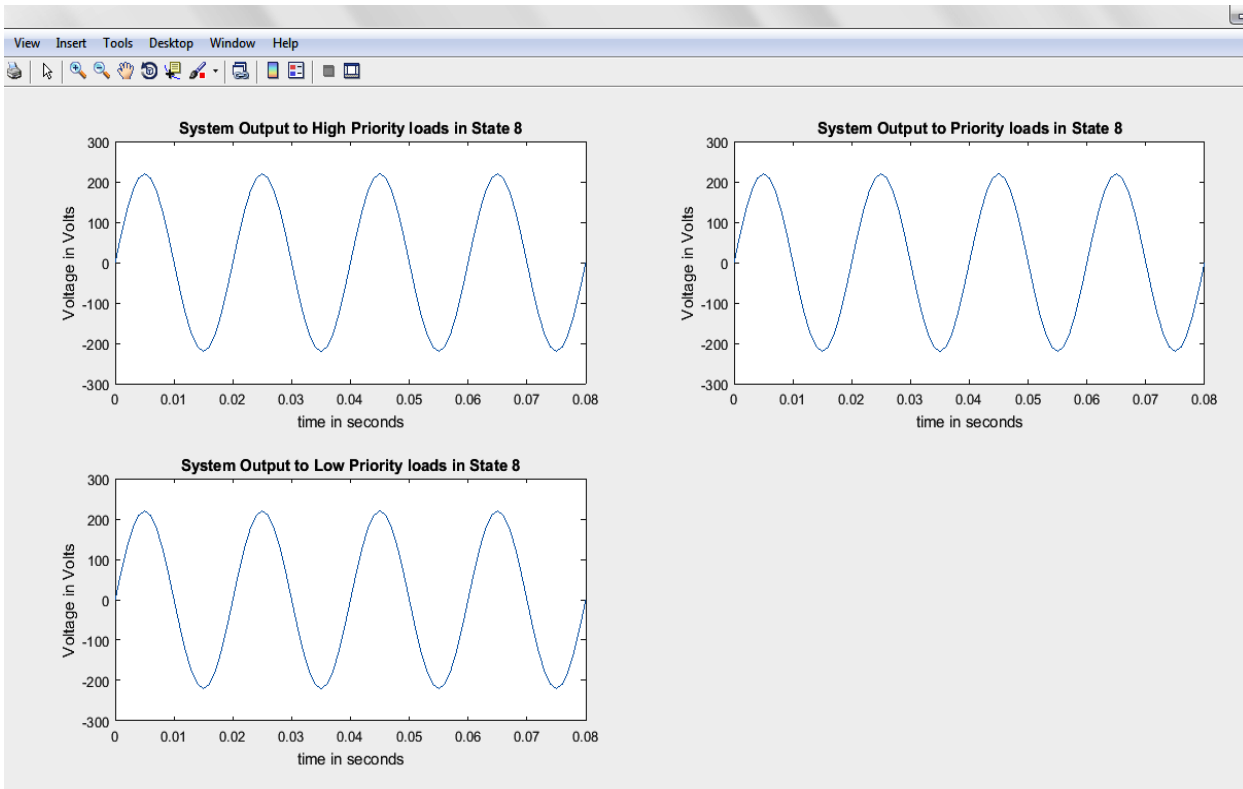

Figure 4.12: Graphical View of sub-grid outputs for figure 4.10

4.2.4.1 Discussion Results for Scenario 4

This scenario will attract additional cost in running the sub-grids, that is, the cost of paying utility bills. It is engaged when there is no other cheaper option available. All the load categories are all supplied as indicated in figure 4.10 to 4.12. During maintenance on the solar plant or the diesel generator, this becomes a very viable option in running the sub-grids, however, it should be minimised to the shortest possible minimum time in order to cut cost.

4.2.5 Scenario 5: Results when Solar is VERYLOW, AUX. HIGH with all other inputs LOW

In this scenario, only the auxiliary (AUX) power from a neighbouring sub-grid is available. The result of the LIA simulation is presented in figures 4.13 to 4.15.

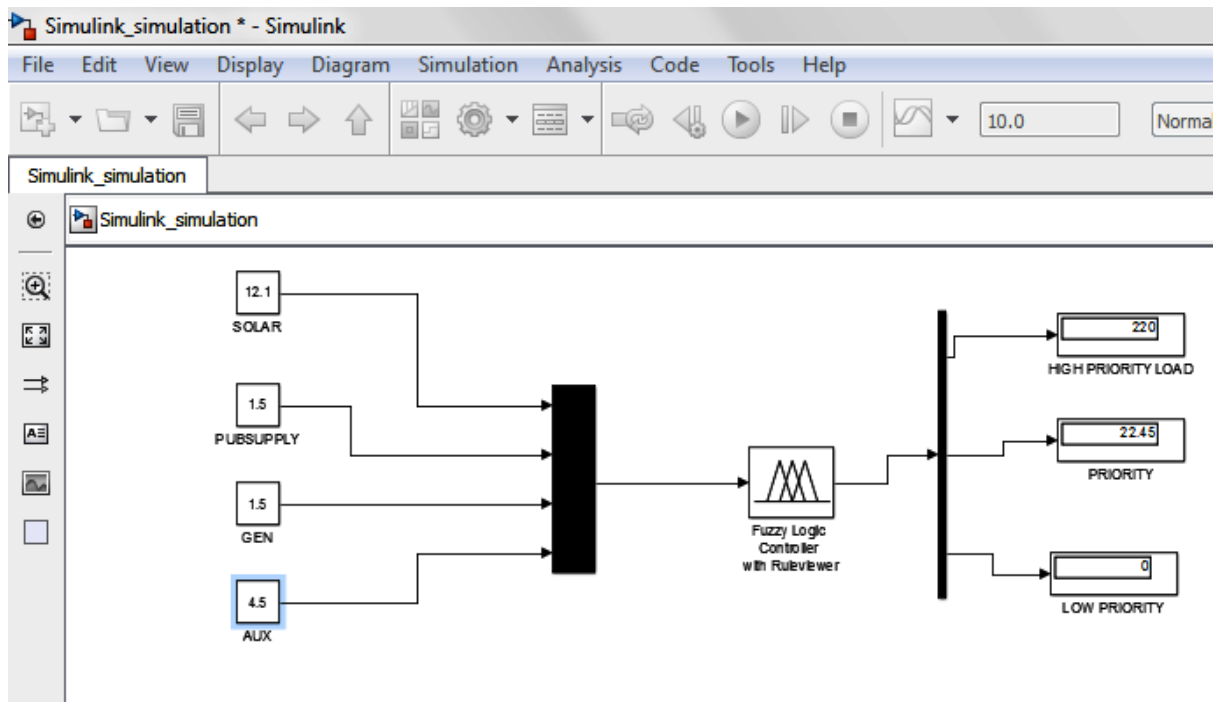

Figure 4.13: Solar input VERYLOW, AUX. HIGH with the other inputs LOW

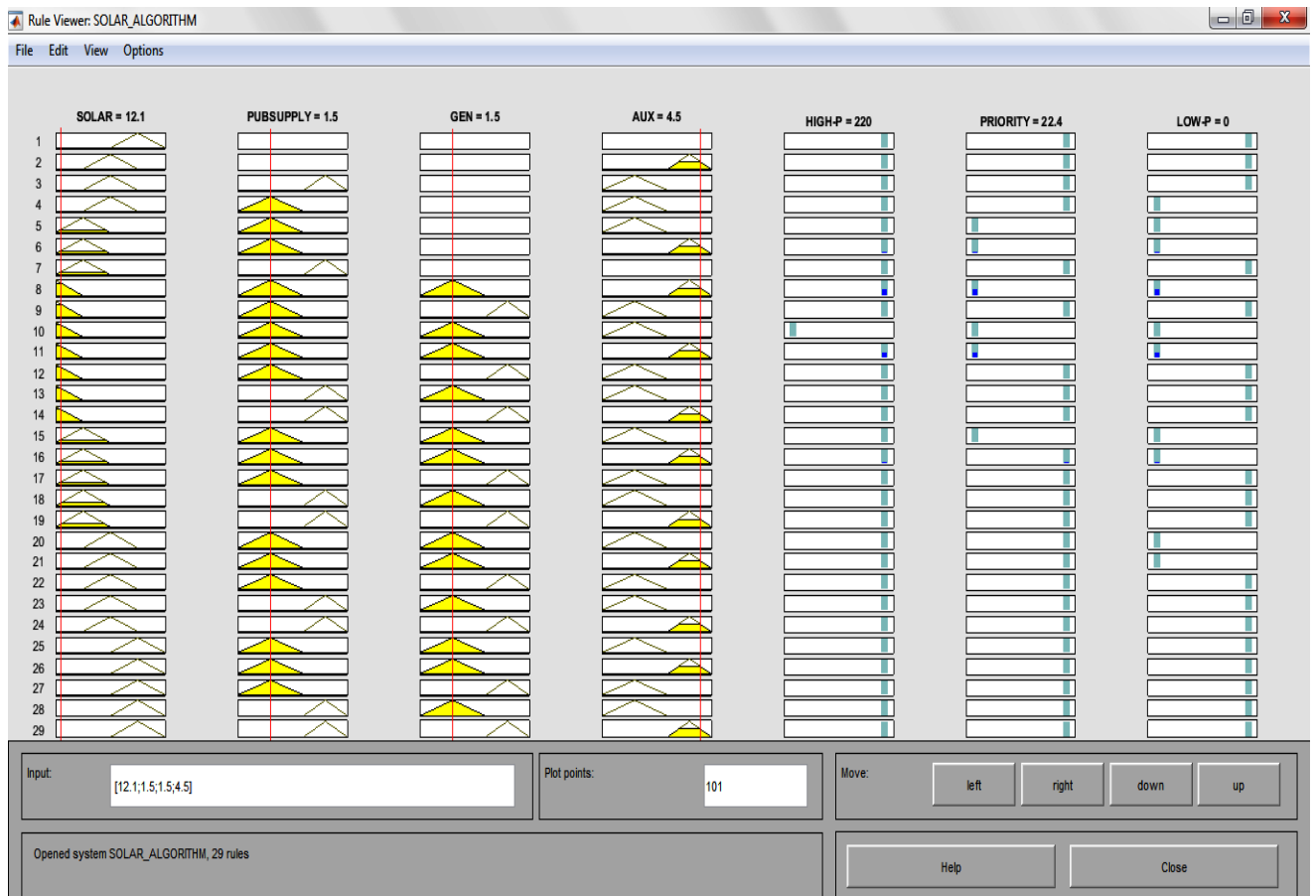

Figure 4.14: Rule View for Figure 4.13 above

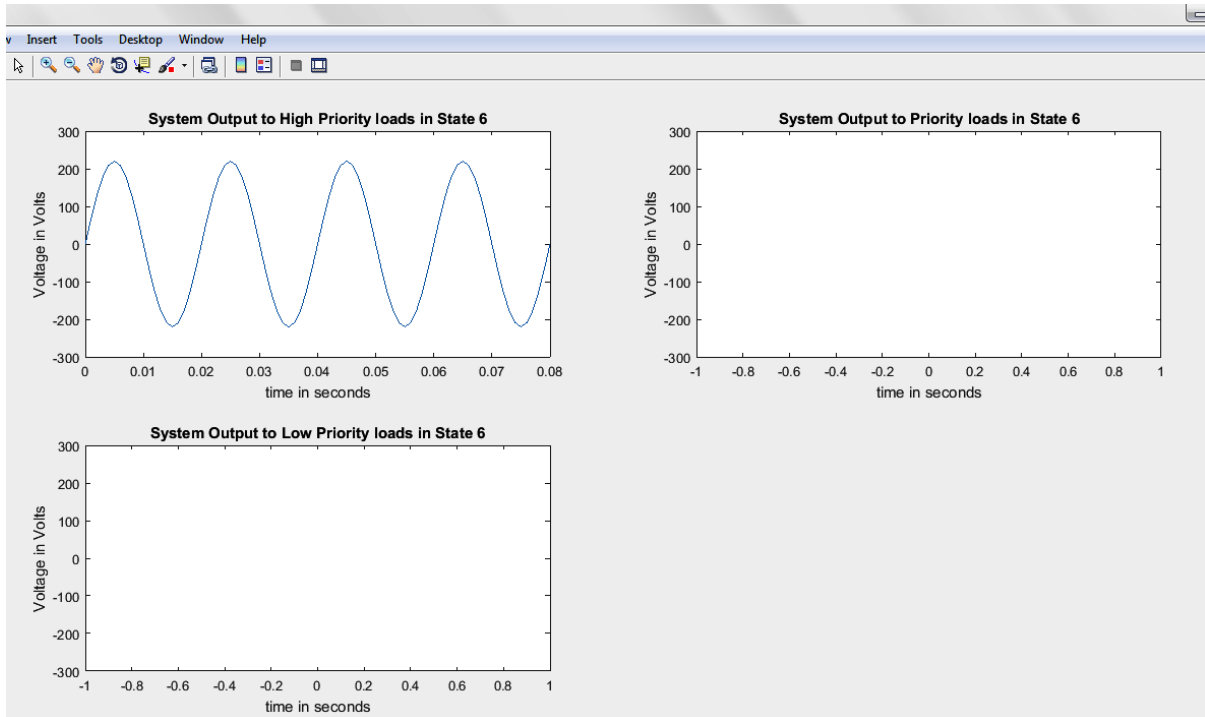

Figure 4.15: Graphical View of sub-grid outputs for fig.4.13

4.2.5.1 Discussion of Results for Scenario 5

The scenario implies that only the auxiliary (AUX) power from a neighbouring sub-grid is available and the expected result is that the output should supply only the high priority loads. Figures 4.13 to 4.15 clearly show that only the high priority loads were supplied. From figures 4.13 and 4.14 the a.c voltage output to the priority loads(pl) is no completely zero but 22.45V, but this is taking as zero output to the load by the LIA as indicated in the output graph in figure 4.15.

4.2.6 Scenario 6: Results when Solar is VERYLOW, GEN. HIGH with all other inputs LOW

In this scenario all the options of electricity supply to the sub-grids are not available, except the diesel generators (GEN.). The result of the simulation of this scenario is presented in figures 4.16 to 4.18.

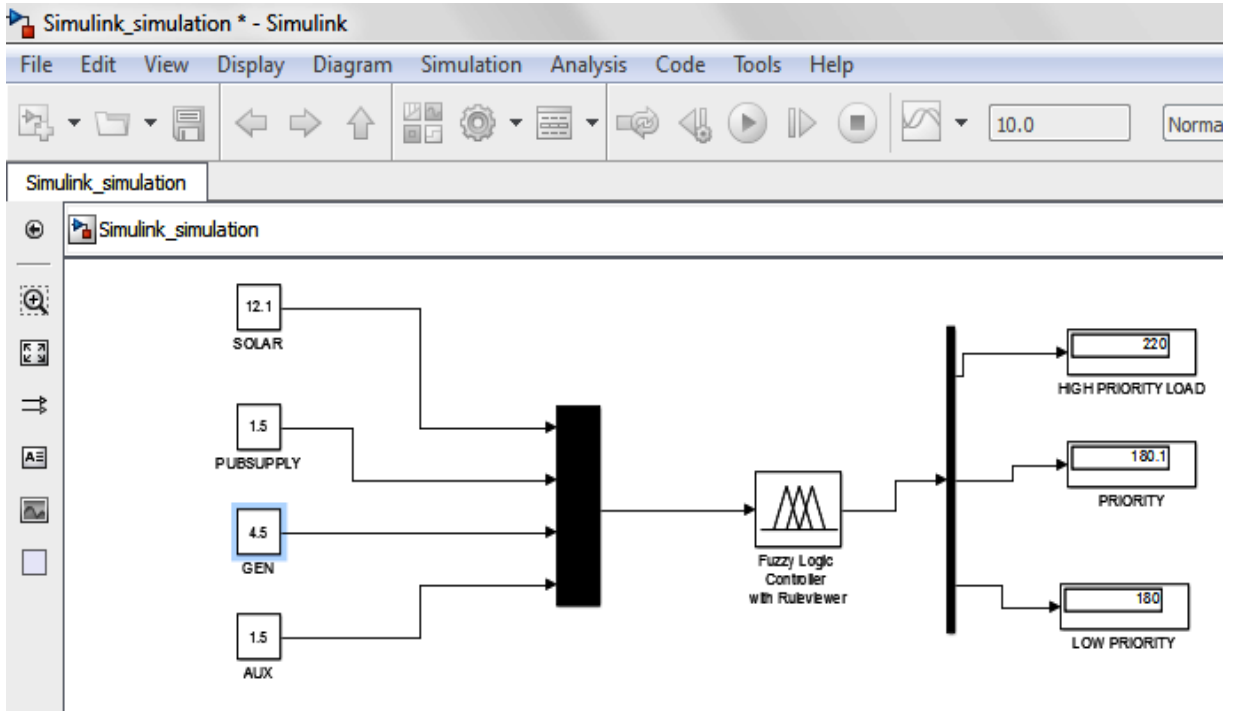

Figure 4.16: Solar input VERYLOW, GEN. HIGH with the other inputs LOW

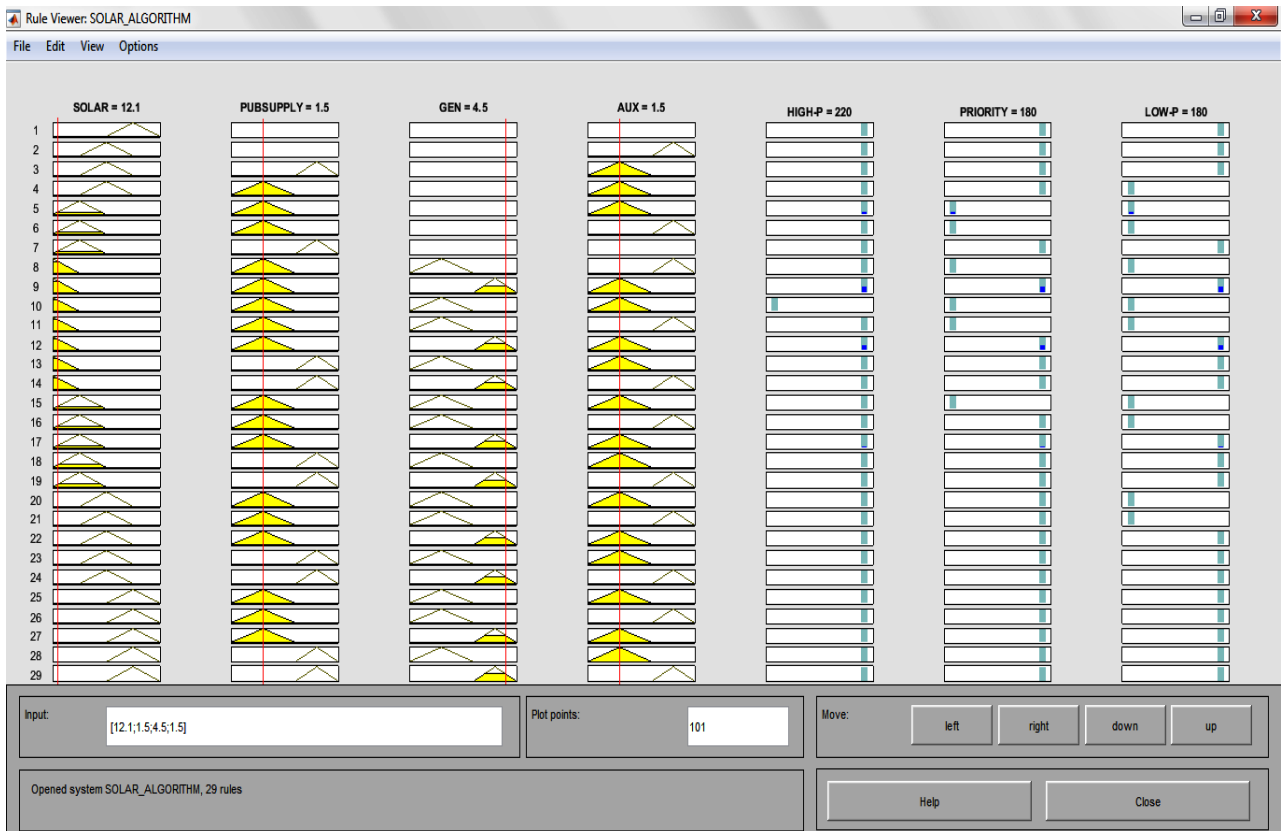

Figure 4.17: Rule View for Figure 4.16

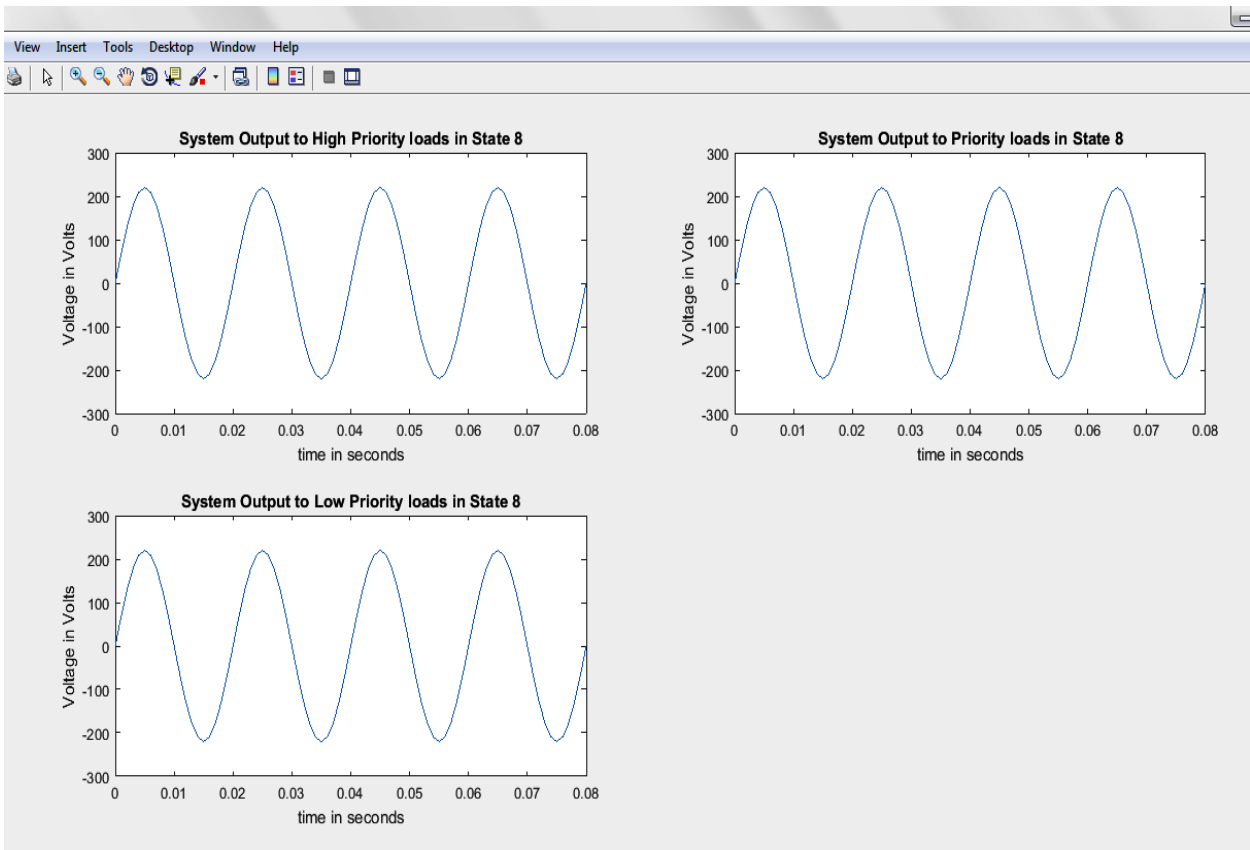

Figure 4.18: Graphical View of sub-grid outputs for fig4.16

4.2.6.1 Discussion of Results for Scenario 6

This scenario will also attract addition running cost to the sub-grids, that is, the cost of diesel. It should only be used in situations where the solar plant, and/or the PUBSUPPLY are not available. However, it can be very useful when the solar plant is undergoing routine maintenance and there is no public utility supply. The microgrid is not designed to fully depend on the diesel generators, rather as a backup power source it is only called up if there is need. Figures 4.16 to 4.18 clearly shows that all the load categories are supplied.

4.2.7 Scenario 7: Results when Solar is LOW, with all other inputs LOW

In this scenario, the solar plant is at a LOW state, while all the other inputs are not available. The results of the simulation of this scenario is presented in figures 4.19 to 4.21.

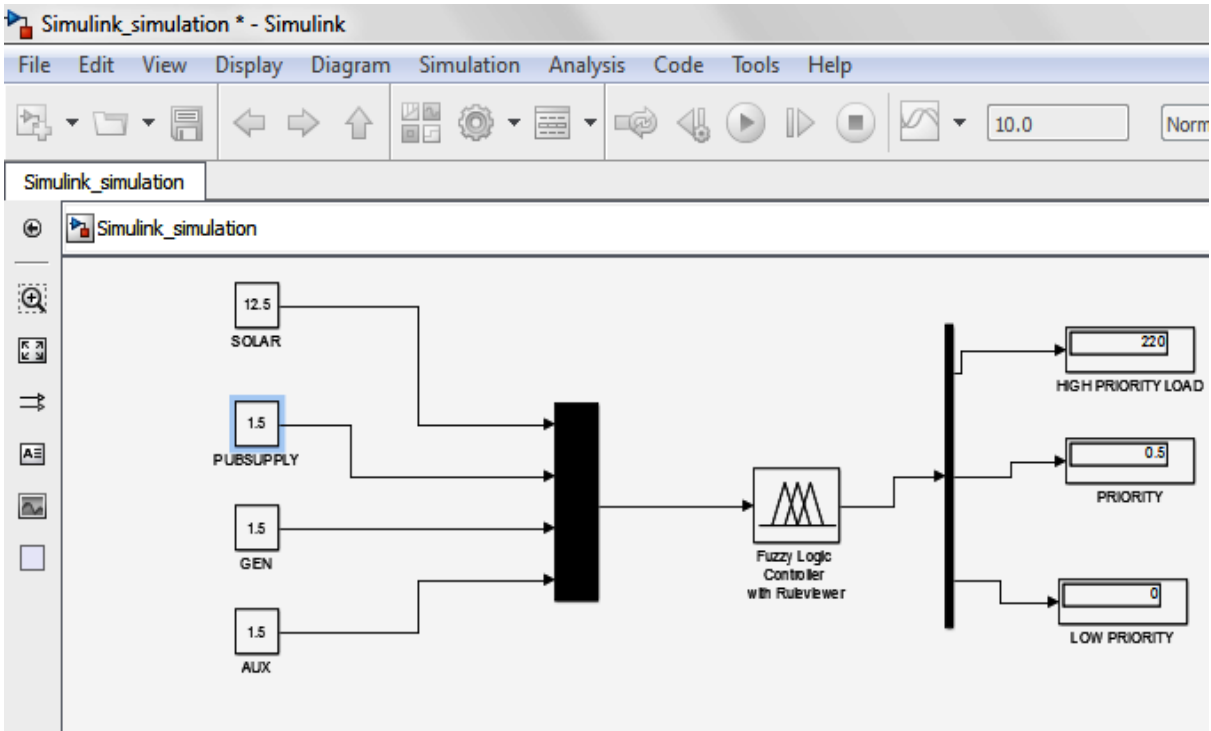

Figure 4.19: Solar input LOW, with the other inputs LOW

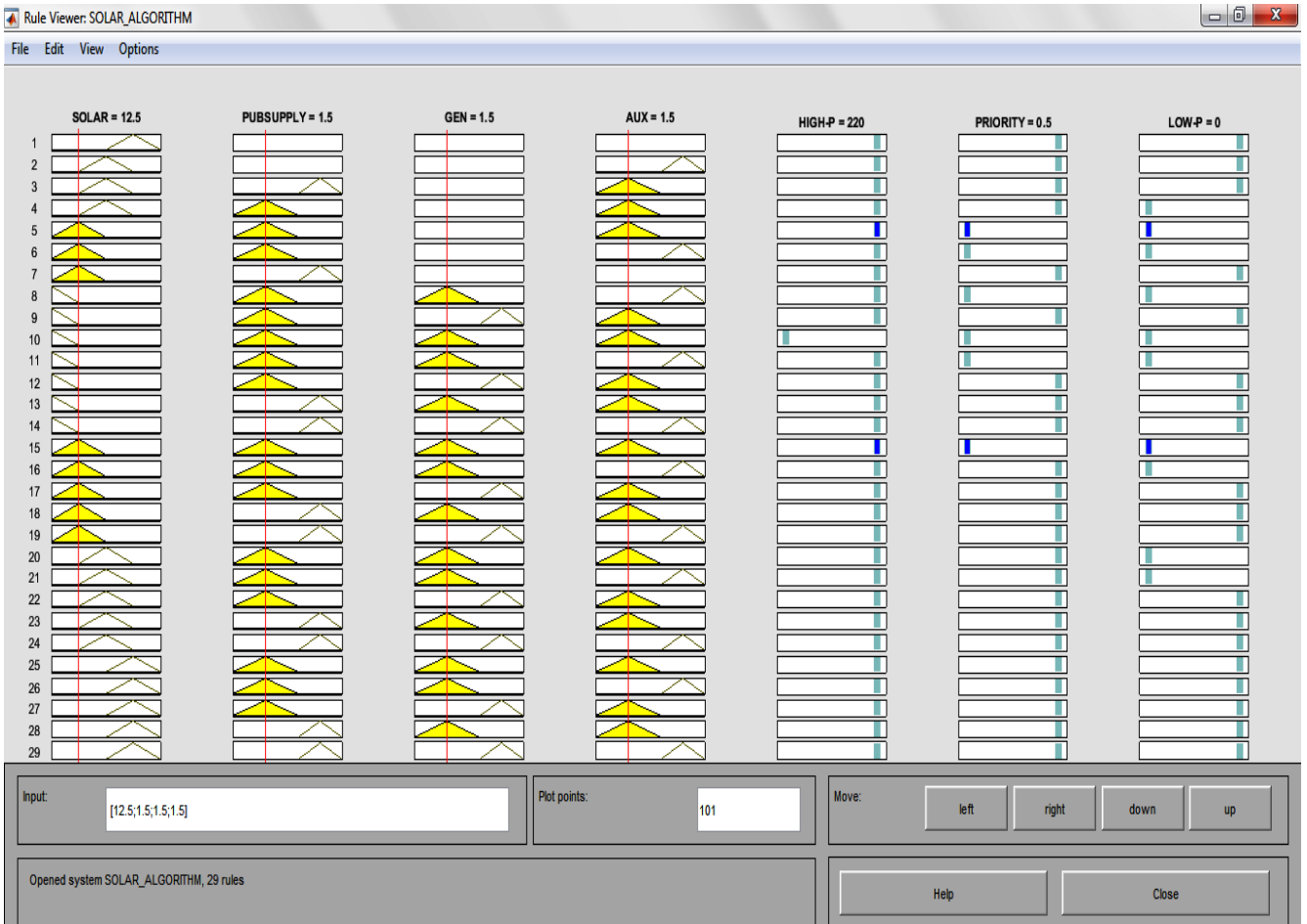

Figure 4.20: Rule View for Figure 4.19 scenario

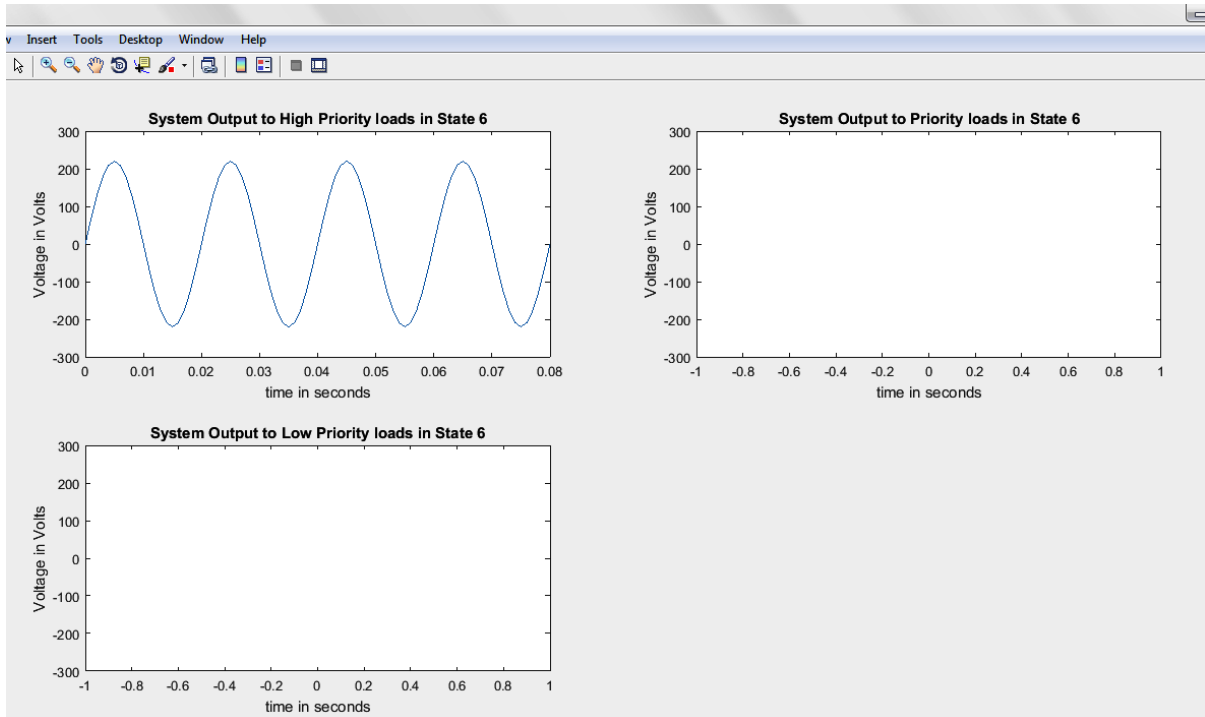

Figure 4.21: Graphical View of sub-grid outputs for figure 4.20

4.2.7.1 Discussion of Results for Scenario 7

In this case, the solar input is expected to supply only to the high priority loads. The sub-grid is meant to manage its available resources without using any other paid power input source. It is expected that the most important loads needed in each of the DG sites, that is, the high priority loads must be supplied. Figures 4.19 to 4.21 shows that only the high priority loads were supplied. This is very important because the LIA protects the BESS to ensure that the battery health is preserved.

4.2.8 Scenario 8: Results when Solar is LOW, AUX. HIGH with all other inputs LOW

In this scenario, the solar plant is a LOW state, and the auxiliary input is available, while the other inputs are not available. The results of the simulation of this scenario are shown in figures 4.22 and 4.23.

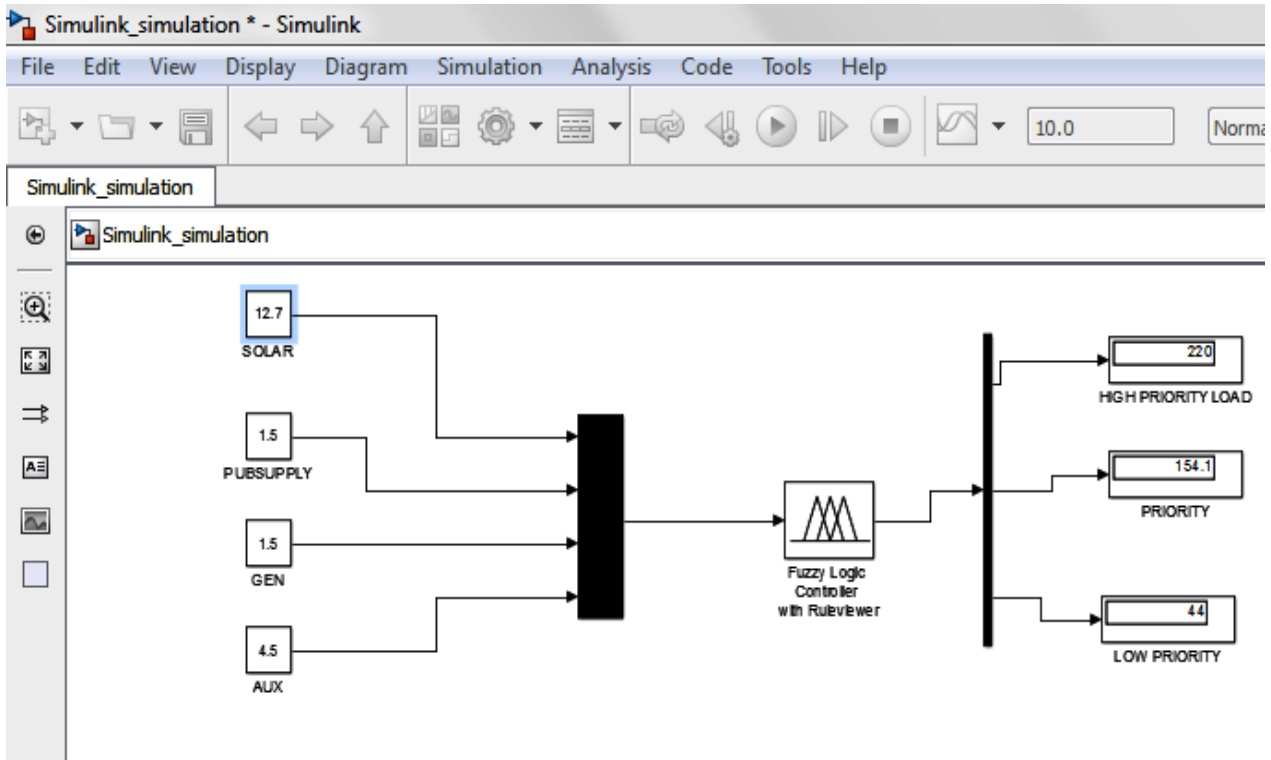

Figure 4.22: Solar input LOW, AUX. HIGH, with the other inputs LOW

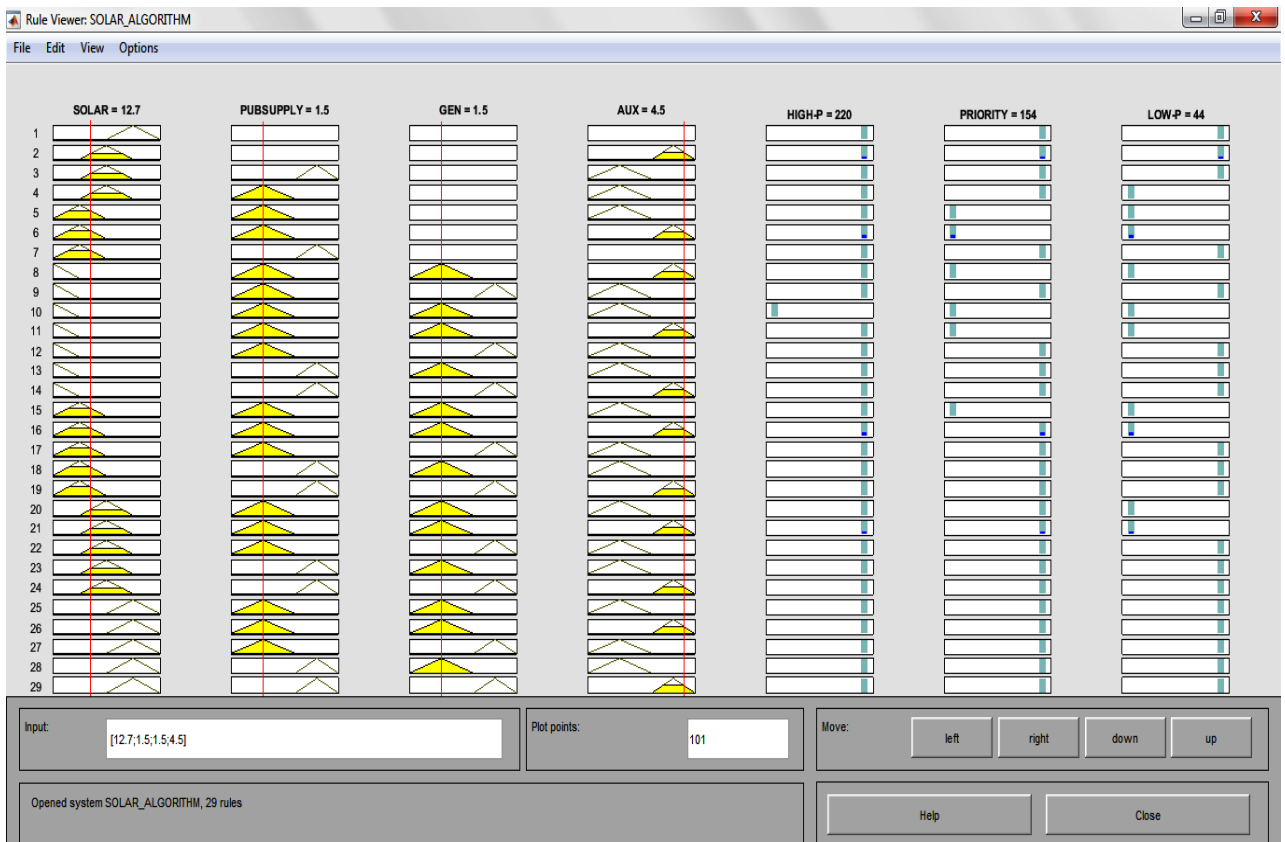

Figure 4.23: Rule View for Figure 4.22

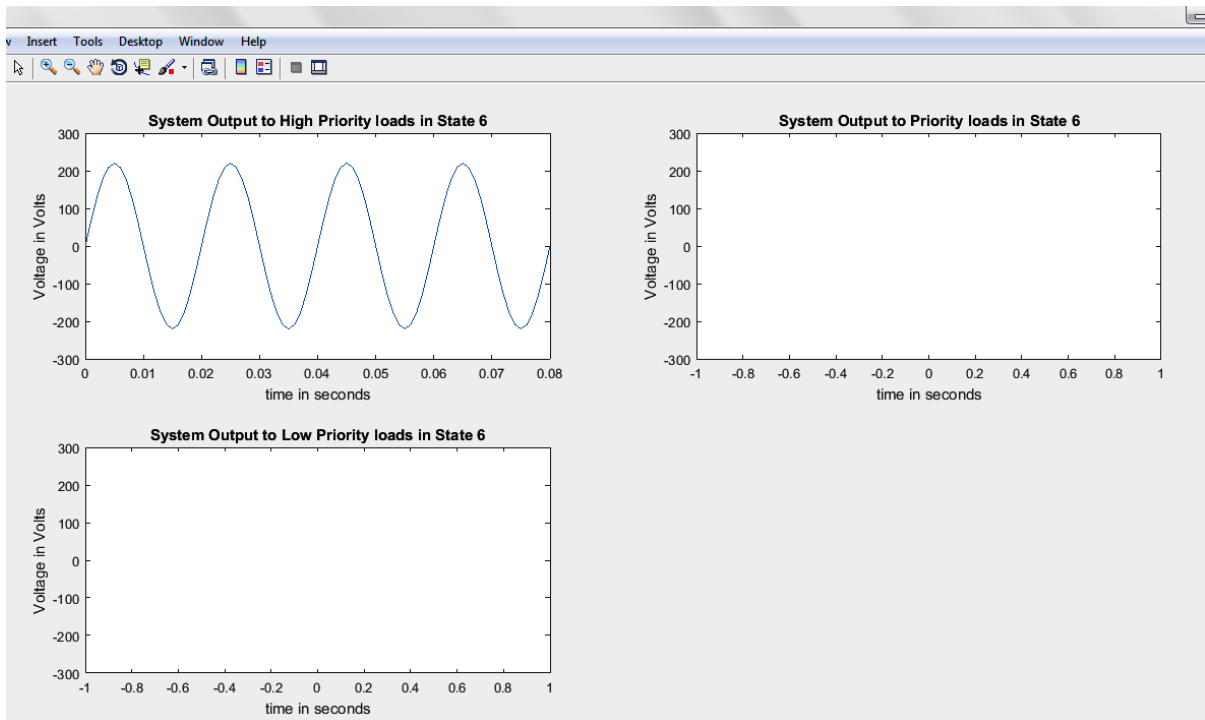

Figure 4.24: Graphical View of micro grid outputs for fig4.22

4.2.8.1 Discussion of Results for Scenario 8

In this particular case, it is expected that only the high priority loads should be supplied. However, in the simulation there was a little deviation, the energy management system attempts to supplied both the high priority and the priority loads. But it was observed that it supplied low voltage (154.1V) to the priority loads, therefore, that was discarded in the real output that goes to the load. Figures 4.22 and 4.23 shows the voltage outputs to the load categories, while figure 4.24 shows the actual output switched to the load. It is important to note that the range of voltage allowed to the loads is 180V to 250V ac. Any disparity from this range is discarded.

4.2.9 Scenario 9: Results when Solar is HIGH, with all other inputs LOW

In this particular scenario the solar plant is a HIGH state, while all the other inputs are not available. The result of the simulation of this scenario is presented in figures 4.25 to 4.27.

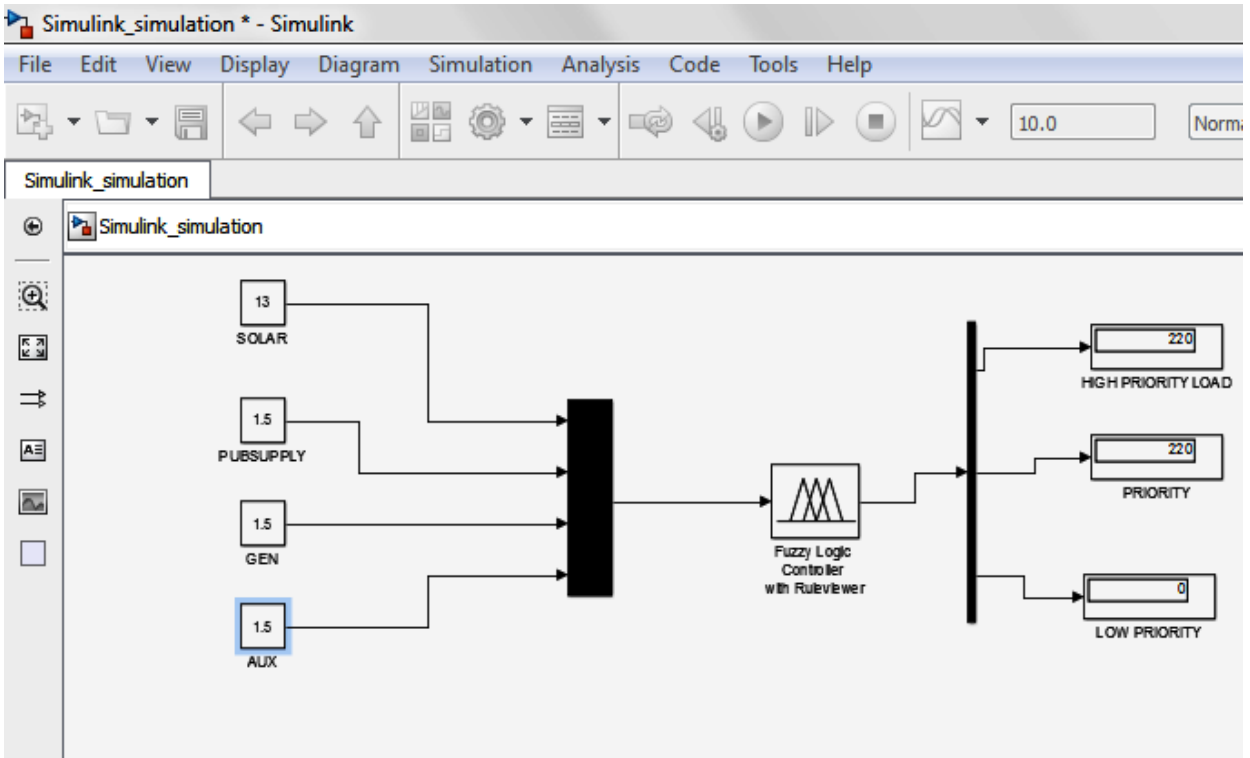

Figure 4.25: Solar input HIGH with the other inputs LOW

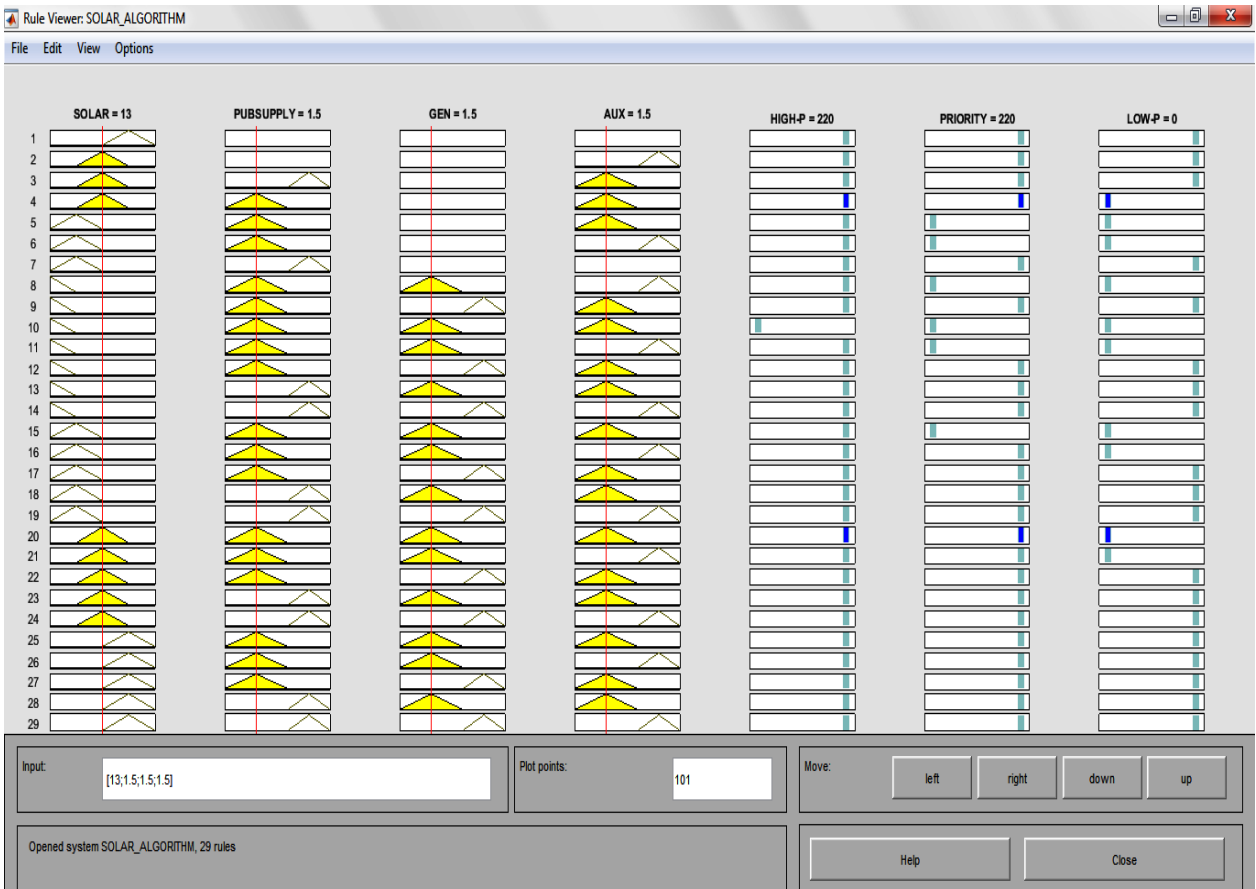

Figure 4.26: Rule View for Figure 4.25 scenario

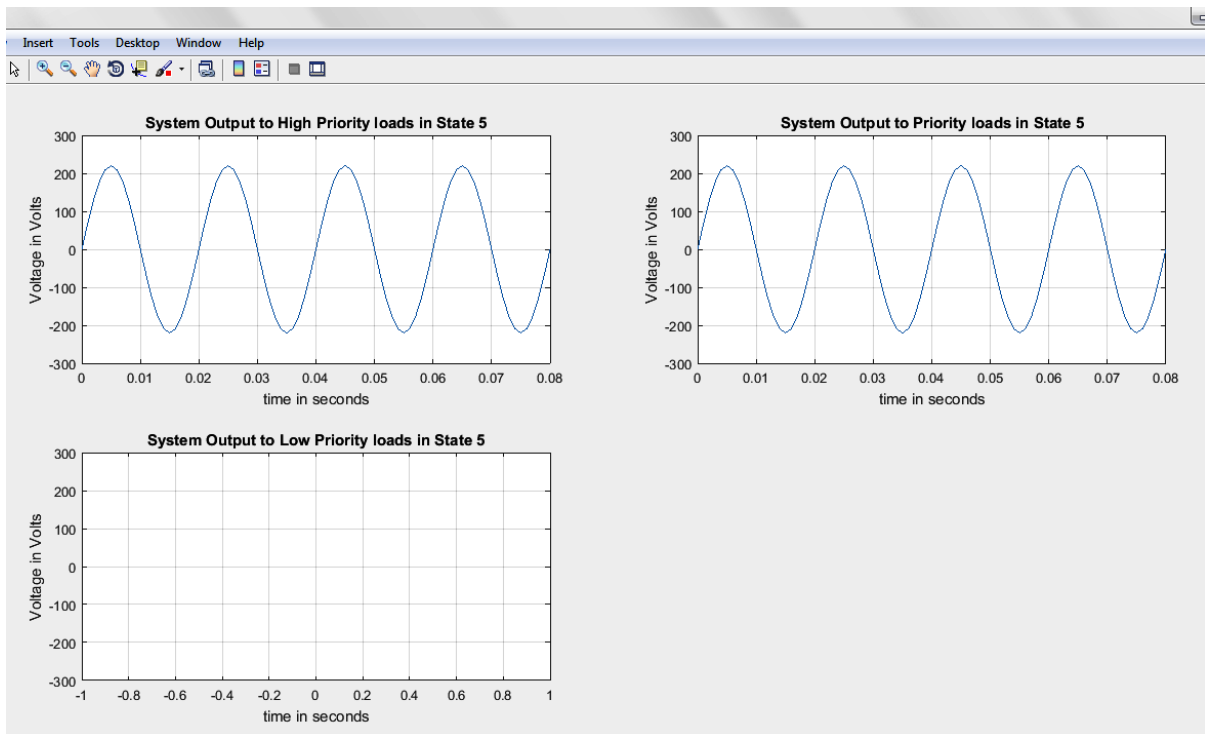

Figure 4.27: Graphical View of micro grid outputs for fig4.26 scenario

4.2.9.1 Discussion of Results for Scenario 9

In this case it is expected that the microgrid run on solar only while supplying to the high priority and priority loads. When simulated the system performed exactly as expected. Figures 4.25 to 4.27 show that only the high priority loads and the priority loads are supplied.

4.2.10 Scenario 10: Results when Solar is HIGH, AUX. is HIGH with all other inputs LOW

In this scenario, the AUX power source from neighbouring DG site is available, however it is expected that only the high priority and the priority loads should be supplied, even with the availability of the auxiliary power. However, figures 4.28 and 4.29 shows that system attempted to supply the less priority loads with a low voltage of 110V, which was discarded as shown in load output graph in figure 4.30.

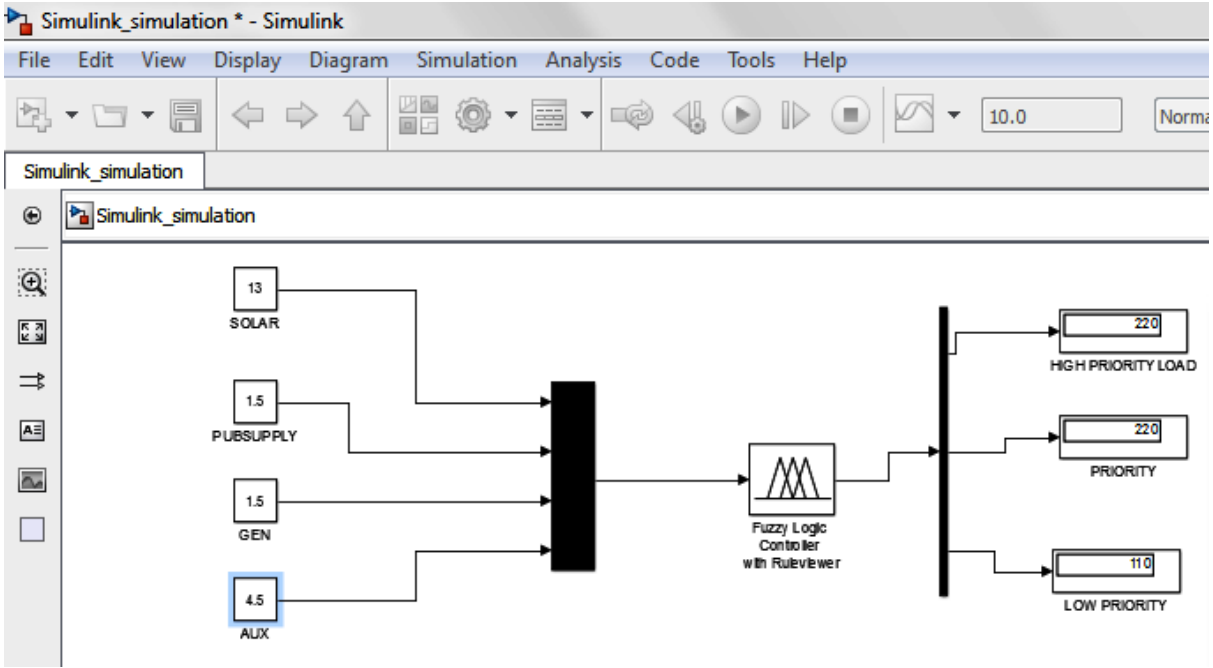

Figure 4.28: Solar input HIGH, AUX. HIGH with the other inputs LOW

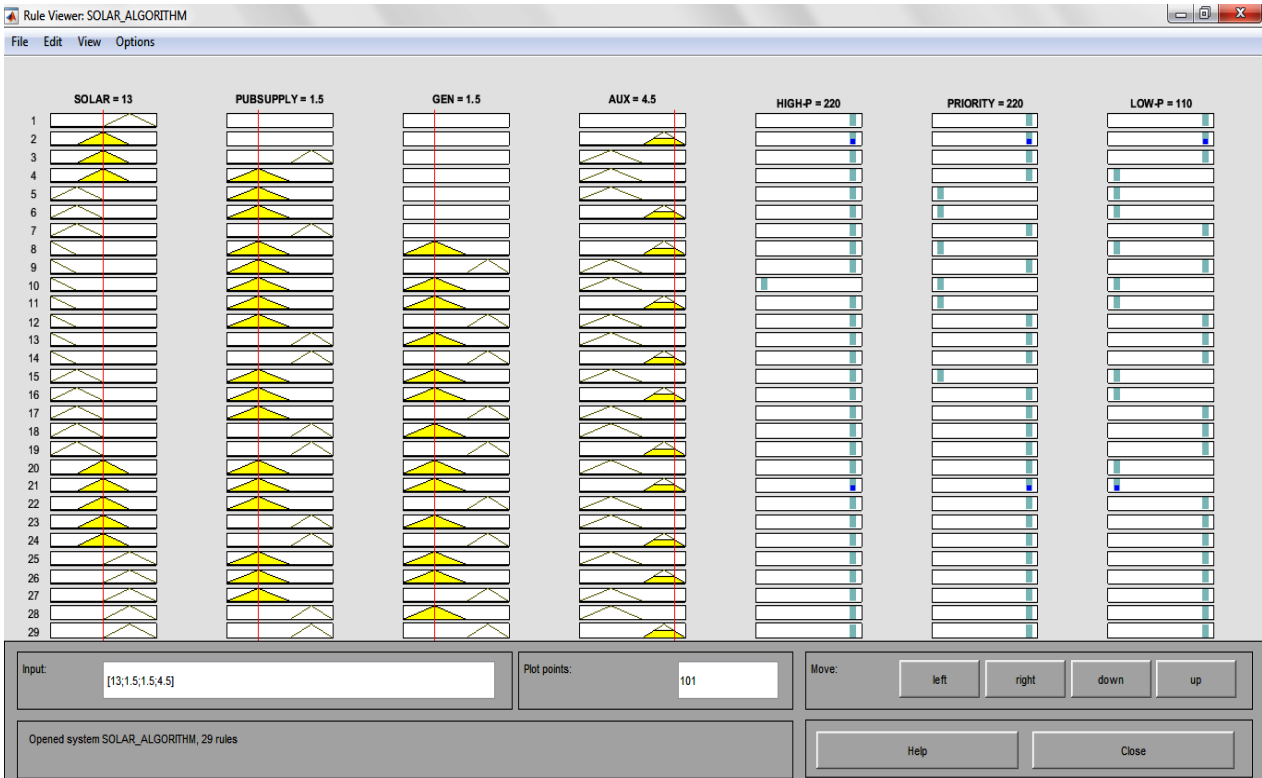

Figure 4.29: Rule View for Figure 4.28 scenario

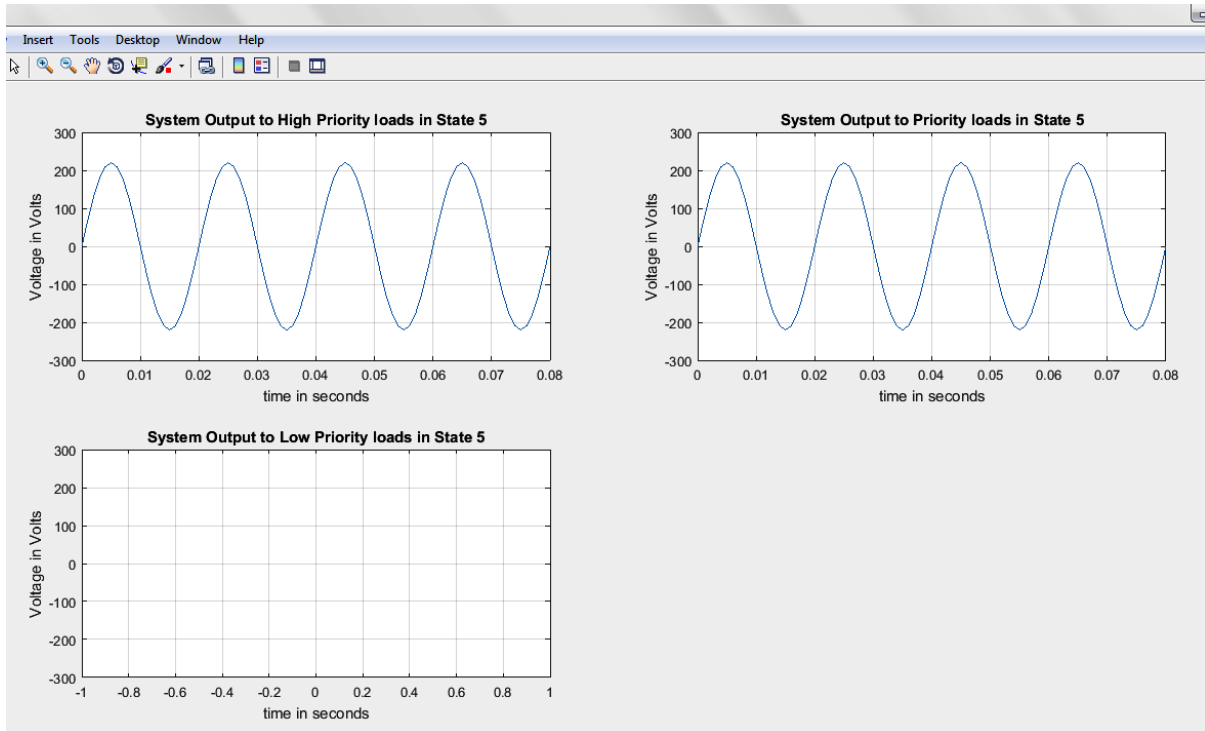

Figure 4.30: Graphical View of sub-grid outputs for fig4.29 scenario

4.2.10.1 Discussion of Results for Scenario 10

In this scenario, the AUX power source from neighbouring DG site is available, however it is expected that only the high priority and the priority loads should be supplied, even with the availability of the auxiliary power. However, in the simulation as shown in figures 4.28 and 4.29 that system attempted to supply the less priority loads with a low voltage of 110V, which was discarded as shown in load output graph in figure 4.30, since it is below the acceptable range (180V -230V).

4.3 Summary of the Results of the System Testing

Table 4.1 shows a summary of the results obtain from the system's response to the 10 possible power input state scenario.

Table 4.1 Summary of Results Obtained from System Testing.

S/N	Test Case Scenarios	Expected System Outputs	Actual System Outputs
1	Solar is VERY HIGH with all other inputs HIGH	All the load categories supplied. The source power source to the micro grid taking from Solar Plant	All the load categories were supplied as shown in the output load graph in figure 4.3
2	Solar is VERYLOW with all other	No load should be supplied	There was no output to

	inputs LOW	at all.	the all the load categories as shown in figure 4.6
3	Solar is VERYHIGH with all other inputs LOW	All the load categories should be supplied.	All the load categories were supplied as shown in Figure 4.9
4	Solar is VERYLOW, PUBSUPPLY HIGH with all other inputs LOW	All to load categories should be supplied from the utility grid	All the load categories were supplied as shown in figure 4.12
5	Solar is VERY LOW, AUX. HIGH with all other inputs LOW	Only the high priority loads should be supplied.	Only the high priority loads were supplied as shown in figure 4.15
6	Solar is VERY LOW, GEN. HIGH with all other inputs LOW	All the load categories should be supplied from the diesel generator.	All the load categories were supplied as shown in figure 4.18
7	Solar is LOW with all other inputs LOW	Only the high priority loads should be supplied.	Only the high priority loads were supplied as shown in figure 4.21
8	Solar is LOW, AUX. HIGH, with all other inputs LOW	Only the high priority loads are supplied.	Only the high priority loads were supplied as shown in figure 4.24
9	Solar is HIGH with all other inputs LOW	The high priority and the priority loads are supplied	High priority and priority loads were supplied as shown 4.27
10	Solar is HIGH, AUX. HIGH with all other inputs LOW	The high priority and the priority loads should be supplied.	High priority and the priority loads are supplied as shown in figure 4.30

4.4 Deduction from Test Result Analysis

The results so far obtained from the testing of the LIA, implies that the EMS has the ability to manage any available input sources to deliver a steady supply to the loads at minimum running cost. In a worst case scenario, it ensures that power supply to the high priority loads (hpl) is not interrupted why monitoring to know when more energy is available. The case in figure 4.4 should not be tolerated within the sub-grids. At least the diesel generator should

always be on standby to supply to the sub-grid, during days with cloudy weather or normal routine maintenance of the solar plants.

CHAPTER FIVE

CONCLUSION

The results of the modelled EMS showed a high level of intelligence and autonomy. The LIA at different test situations was able to take the accurate decision without any human interference. The system has the ability to manage the available input sources to deliver a steady supply to the loads at minimum running cost. It ensures that in a worst case scenario steady power is supplied to the high priority loads. The diesel generator should always be on stand-by to take over the running of the micro grid if there is any need for it, especially during the days with cloudy weather or during normal routine maintenance of the solar plant. Once again, when this micro grid is physically deployed, it will enhance improved quality of research, reduction in running cost and provide better learning environments.

5.1 Contributions to Knowledge

The major contributions of this dissertation are;

- It introduced the used of multi-function intelligent Agent for Energy management in microgrids instead of multi-agents.
- It also introduces a unique approach to energy management in microgrids by adopting intelligent agent technology.
- It presented a smart way of mapping microgrid energy inputs to appropriate load categories.

5.2 Recommendations

Further research in the areas of Microgrid and Microgrid energy management will proffer solution to current power woes of Nigerian universities and the nation at large. It is highly recommended that more Masters Students and PhD candidates should be encouraged to take up various aspects of researches in the area of microgrid technology. These research areas include better battery energy storage system (BESS), and several other energy storage techniques, microgrid control techniques, microgrid energy integration, microgrid security e.t.c. Also, more researches should be focused on integrating several upcoming technologies like the internet of things (IoT) into microgrid designs. When serious attention is paid to

microgrid technology, it will go a long way in alleviating the current power woes of Nigerian universities and country at large. More so, a lot of employment potentials exist in microgrid technology and it should given a focus attention.

REFERENCES

- Albertos, P., & Antonio, S. (1998). *Fuzzy Logic Controllers, Advantages and Drawbacks*. Valencia: Universidad politencnica de Valencia.
- Al-Odienat, A. I., & Al-Lawama, A. A. (2008). The Advantages of PID Fuzzy Controllers Over The Conventional Types. *American Journal of Applied Science* , V (6), 653 -658.
- Amini, M. H., Nabi, B., & Haghifam, M. R. (2013). Load management using multi-agent systems in smart distribution network. *2013 IEEE Power & Energy Society General Meeting* (pp. 1-5). IEEE.
- Amos, A. O., Zekeri, A., & Idowu, H. A. ((2017)). The power sector and its impacts on industrialization of businesses in Nigeria. *Archives of Business Research* , 5 (12).
- Arcos-Aviles, D., Pascual, J., Marroyo, L., Sanchis, P., & Guinjoan, F. (2018). Fuzzy logic-based energy management system design for residential grid-connected microgrids. *IEEE Transactions on Smart Grid* , IX (2), 530-543.
- Augustine, C., & Nnabuchi, M. N. (2009). Correlation between sunshine hours and global solar radiation in Warri, Nigeria. *Pacific Journal of Science and Technology* , X (2), 574-579.
- Bih, J. (2006). Paradigm shift-an introduction to fuzzy logic. *IEEE potentials* , 6-21.
- Burgin, M., & Dodig-Crnkovic, G. (2009). *A systematic approach to artificial agents*. Virginia: arXiv preprint arXiv:0902.3513.
- Catterson, V. M., Davidson, E. M., & McArthur, S. D. (2012). Practical applications of multi-agent systems in electric power systems. *European Transactions on Electrical Power*, 22(2), (pp. 235-252.). European Transactions on Electrical Power.
- Chevrie, F., & Guely, F. (1998). *Fuzzy Logic*. Rueil-Malmaison: Groupe Schneider.
- Costa, B. S., Clauber, G. B., & Luiz, A. H. (2012). A multistage fuzzy controller: Toolbox for industrial applications. *IEEE International Conference on Industrial Technology*, (pp. 1142-1147).
- Das, S. K., Kumar, A., Das, B., & Burnwal, A. P. (2013). On soft computing techniques in various areas. *Int J Inform Tech Comput Sci*, 3 , 59-68.
- Ernie, H. (2013). *Introduction to Micro grids*. Virginia: securicon.
- Etukudor, C., Ademola, A., & Olayinka, A. (2015). The Daunting Challenges of the Nigerian Electricity Supply Industry. *Journal of Energy Technologies and Policy* , V (9), 25-32.

Farouk, N., & Sheng, L. (2012). Design and Implementation of a Fuzzy Logic Controller for Synchronous Generator. *Research Journal of Applied Sciences, Engineering and Technology* , IV (20), 4126-4131.

Fikari, S. G. (2015). *Modelling and Simulation of an Autonomous Hybrid Power System*. Uppsala Sweden: Uppsala University.

Frankovič, B., & Oravec, V. (2005). *Design of the agent-based intelligent control system*. Hungarica: Acta Polytechnica Hungarica.

Ganesan, S. P.-P. (2017). Study and analysis of an intelligent microgrid energy management solution with distributed energy sources. *Energies* , 1419.

Garrab, A., Bouallegue, A., & Bouallegue, R. (2017). An agent based fuzzy control for smart home energy management in smart grid environment. *International Journal of renewable energy research* , VII (2), 599-612.

Gaurav, A. K., & Kaur, A. (2012). Comparison between conventional PID and fuzzy logic controller for liquid flow control: Performance evaluation of fuzzy logic and PID controller by using MATLAB/Simulink. *International Journal of Innovative Technology and Exploring Engineering (IJITEE) 1(1)* , i (1), 84-88.

Gibin, M. P., Twinkle, T., Juliya, S., Miranda, T., & Gopakumar, P. (2016). Hybrid Ring MicroGrid with co-ordinated Energy Management Scheme. *Science Direct, Elsevier, Procedia Technology 25* , 793-800.

Goyal, M., Arindam, G., & Firuz, Z. (2013). Power Sharing Control with Frequency Droop in a Hybrid Microgrid. *IEEE Power & Energy Society General Meeting* , 1-5.

Guena, T., & Leblanc, P. (2006). How depth of discharge affects the cycle life of Lithium-metal-polymer batteries. *Guena, T., & Leblanc, P. (2006, September). How depth of discharge affects the cycle life of lithium-metal-polymer batteries. In INTELEC 06-Twenty-Eighth International Telecommunications Energy Conference* (pp. 1-8). IEEE.

Gupta, P. (2017). Applications of Fuzzy Logic in Daily life. *International Journal of Advanced Research in Computer Science* , VIII (5).

Herzog, A. V., Lipman, T. E., & Kammen, D. M. (2001). *Renewable Energy Sources*. California: Encyclopaedia of Life Support Systems(EOLSS).

Hsu, C., & Goldberg, H. S. (1999). Knowledge-mediated retrieval of laboratory observations. *In Proceedings of the AMIA Symposium* (pp. 809-813). Philadelphia: American Medical Informatics Association.

Hurwitz, E., & Marwala, T. (2007). *Multi-agent modeling using intelligent agents in the game of lerpa*. Crsytal City Virginia: arXiv preprint arXiv:0706.

Ilenikhan, P., & Ezemonye, L. (2010). *Solar Energy Application in Nigeria*. Montreal: WEC.

Khosravi, H. (2011). *Intelligent Agents*. Springs.

- Lanzola, G., Gatti, L., Falasconi, S., & Stefanelli, M. (1999). A framework for building cooperative software agents in medical applications. *Artificial intelligence in medicine* , XVI (3), 223-249.
- Latham, & Watkins. (2016). *Nigerian Power Sector: Opportunity and Challenges for Investment in 2016*. Client White Paper, Latham & Watkins African Practice.
- Lee, E. K., Shi, W., Gadh, R., & Kim, W. (2016). Design and implementation of a microgrid energy management system. *Sustainability* , VIII (11), 1143.
- Llanos, J., Morales, R., Nunez, A., Saez, D., Lacalle, M., Marin, L., et al. (2017). Load Estimation for Micro grid Planning Based on a Self-Organizing Map Methodology. *Applied Soft Computing* , 53, 323-335.
- Logenthiran, T., Srinivasan, D., & Khambadkone, A. M. (2011). Multi-agent system for energy resource scheduling of integrated microgrids in a distributed system. *Electric Power Systems Research* , 81(1), , 81 (1), 138-148.
- Longe, O. M., Rao, N. D., Omowole, F., Oluwalami, A. S., & Oni, O. T. (2017). A Case Study on Off-grid Microgrid for Universal Electricity Access in the Eastern Cape of South Africa. *International Journal of Energy Engineering* , 55-63.
- MathWorks. (2018). *MATHWORKS*. Retrieved April 18, 2019, from MATHWORKS: <https://uk.mathworks.com/help/fuzzy/release-notes.html>
- Mozafari, S. (2016). Design and Simulation of a hybrid Micro grid for Bisheh Village. *International Journal of Renewable Energy Reserach (IJRER)* , 1, 199-211.
- Naderii, A., Ghasemzadehii, H., Pourazar, A., & Aliasgharyii, M. (2009). Design of a Fuzzy Controller Chip with New Structure, Supporting Rational-Powered Membership Functions. *AUT Journal of Electrical Engineering* , 41 (2), 65-71.
- Neumaier, A. (2016). *Artificial Intelligence, Mathematics and Conciousness*. Vienna: Seminarzentrum FOCUS(Vienna).
- Oghogho, I. (2014). Solar Energy Potential and its Development for Sustainable Energy Generation in Nigeria: A Road Map to Achieving this Feat. *International Journal of Engineering and Management Science* , 5 (2), 61-67.
- Parsons, S., & Wooldridge, M. (2002, September 1). Game theory and decision theory in multi-agent systems. *Autonomous Agents and Multi-Agent Systems* , V (3), pp. 243-254.
- Rehtanz, C. (2003). *Autonomous systems and intelligent agents in power system control and operation*. Saleem: Springer Science & Business Media.
- Robert, L., Abaas, A., Chris, M., John, S., Jeff, D., Ross, G., et al. (2002). *Integration of Distributed Energy Sources, White Paper on the CERTS Micro grid Concept*. California: Consortium for Electric Realibility Technology Solutions.

- Roine, L., Therani, K., Manjili, Y. S., & Jamshidi, M. (2014). Microgrid energy management system using fuzzy logic control. *World Automation Congress (WAC)* (pp. 462-467). IEEE.
- Rovatsos, M. (2016). *Intelligent Agents and their Environments*. Edinburgh: School of Informatics University of Edinburgh.
- Ruban, A. A., Rajasekaran, G. M., & Rajeswari, N. (2015). Implementation of energy management system to PV-Wind hybrid power generation system for DC microgrid applications. *Int Res J Eng Technol* , II (8), 204-210.
- Russell, S. J., & Norvig, P. (2016). *Artificial intelligence: a modern approach*. Malaysia: Pearson Education Limited.
- Sakthivel, B., & Devaraji, D. (2015). Modelling, Simulation an Performance Evaluation of Solar PV- Wind Hybrid Energy Systems. *IEEE Electrical Electronics Signals Communication and Optimization* , 1-6.
- Saleem, A., Heussen, K., & Morten, L. (2009). Agent services for situation aware control of power systems with distributed generation. *2009 IEEE Power & Energy Society General Meeting*. (pp. 1-8). Verlag: IEEE.
- Smathers, D. C., & Goldsmith, S. Y. (2001). *Agent concept for intelligent distributed coordination in the electric power grid*. Albuquerque: SANDIA Report, SAND2000-1005.
- Spotnitz, R. (2003). Simulation of capacity fade in lithium-ion batteries. *Journal of Power Sources* , 113 (1), 72-80.
- Sugeno, M., & Yasukawa, T. (1993). A fuzzy-logic-based approach to qualitative modeling. *IEEE Transactions on fuzzy systems* , I (1), 7.
- Swaminathan, G., Sanjeevikumar, P., Ramesh, V., Umashanka, S., & Mihet-Popa, L. (2017). Study and Analysis of an Intelligent Micro grid Energy Management Solutions with Distributed Energy Sources. *Energies (MPDI)* , 10 (9), 1419.
- Teo, T. T., Logenthiran, T., Woo, W. L., & Abidi, K. (2016, November). Fuzzy logic control of energy storage system in microgrid operation. *IEEE Innovative Smart Grid Technologies-Asia (ISGT-Asia)* , 65-70.
- Theraja, B., & Theraja, A. *A Text book on Electrical Technology*. S.Chand & Company Ltd.
- Umarikar, A. (2003). *Fuzzy Logic and brief overview of its applications*. Suecia: University Västerås.
- Wemstedt, F., & Davidsson, P. (2002). An agent-based approach to monitoring and control of district heating systems. *In International Conference on Industrial, Engineering and Other Applications of Applied Intelligent Systems* (pp. 801-811). Heidelberg: Springer, Berlin, Heidelberg.
- Wooldridge, M. (. (2009). *An introduction to multiagent systems*. Denmark: John Wiley & Sons.

Wooldridge, M. (1999). *Intelligent agents, Multiagent systems*.

Wooldridge, M. (2003). *Reasoning about rational agent*. MIT press.

Xu, Z., Gordon, M., Lind, M., & Ostergaard, J. (2009). Towards a Danish power system with 50% wind—Smart grids activities in Denmark. *IEEE Power & Energy Society General Meeting* (pp. 1-8). Denmark: IEEE.

Zaidi, A. A., Zia, T., & Kupzog, F. (2010). Automated demand side management in microgrids using load recognition. *2010 8th IEEE International Conference on Industrial Informatics* (pp. 774-779). IEEE.

Zhao, Z. (2012). *Optimal energy management for microgrids*.

APPENDIX A: PICTURES OF SOME ELECTRICAL LOADS, THE DIESEL GENERATOR FROM SOME OF THE SUB-GRIDS

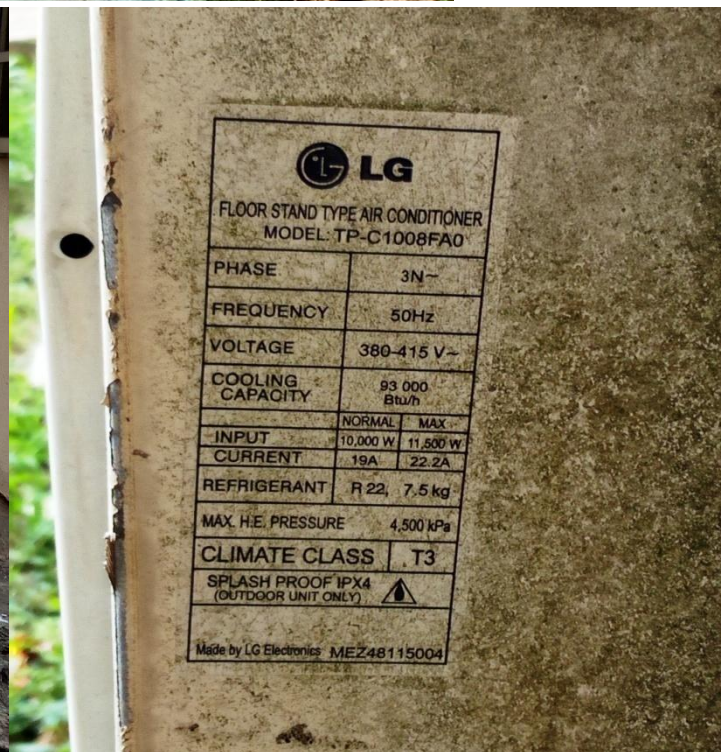

APPENDIX B : MATLAB CODE TO TESTING IMPLEMENTED MODEL

```
SOLAR = input('Enter the state of solar HIGH/LOW: ');
PUB_SUP = input('Enter the state of PUBLIC SUPPLY HIGH/LOW: ');
GEN = input('Enter the state of generator HIGH/LOW: ');
AUX = input('Enter the state of AUX_Supply HIGH/LOW: ');
if (SOLAR)== 2
figure
x = 0:0.001:0.08;
HPL = 220*sin(2*pi*50*x);
PL = 220*sin(2*pi*50*x);
LPL = 220*sin(2*pi*50*x);
subplot (2,2,1)
plot(x,PL)
xlabel('time in seconds')
ylabel('Voltage in Volts')
title('System Output to High Priority Loads in State 1')
grid on
subplot (2,2,2)
plot(x,PL)
xlabel('time in seconds')
ylabel('Voltage in Volts')
title('System Output to Priority Loads in State 1')
grid on
subplot (2,2,3)
plot(x,LPL)
xlabel('time in seconds')
ylabel('Voltage in Volts')
title('System Output to Low Priority Loads in State 1')
grid on
end
if (SOLAR)== 1 && (PUB_SUP)== 1
figure
x = 0:0.001:0.08;
HPL = 220*sin(2*pi*50*x);
PL = 220*sin(2*pi*50*x);
LPL = 220*sin(2*pi*50*x);
subplot (2,2,1)
plot(x,PL)
xlabel('time in seconds')
ylabel('Voltage in Volts')
title('System Output to High Priority Loads in State 2')
grid on
subplot (2,2,2)
plot(x,PL)
xlabel('time in seconds')
ylabel('Voltage in Volts')
title('System Output to Priority Loads in State 2')
```

```

grid on
subplot (2,2,3)
plot(x,LPL)
xlabel('time in seconds')
ylabel('Voltage in Volts')
title('System Output to Low Priority Loads in State 2')
grid on
end
% If (SOLAR is HIGH) and (AUX is HIGH) then
% (HIGH-P is HIGH)(PRIORITY is HIGH)(LOW-P is HIGH) (1)
if (SOLAR)== 1 && (AUX)== 1
figure
x = 0:0.001:0.08;
HPL = 220*sin(2*pi*50*x);
PL = 220*sin(2*pi*50*x);
LPL = 220*sin(2*pi*50*x);
subplot (2,2,1)
plot(x,PL)
xlabel('time in seconds')
ylabel('Voltage in Volts')
title('System Output to High Priority loads in State 3')
grid on
subplot (2,2,2)
plot(x,PL)
xlabel('time in seconds')
ylabel('Voltage in Volts')
title('System Output to Priority loads in State 3')
grid on
subplot (2,2,3)
plot(x,LPL)
xlabel('time in seconds')
ylabel('Voltage in Volts')
title('System Output to Low Priority loads in State 3')
grid on
end
% If (SOLAR is HIGH) and (PUBSUPPLY is HIGH) and (AUX is LOW)
% then (HIGH-P is HIGH)(PRIORITY is HIGH)(LOW-P is HIGH) (1)
if (SOLAR)== 1 && (PUB_SUP)== 1 && (AUX)== 0
figure
x = 0:0.001:0.08;
HPL = 220*sin(2*pi*50*x);
PL = 220*sin(2*pi*50*x);
LPL = 220*sin(2*pi*50*x);

subplot (2,2,1)
plot(x,PL)
xlabel('time in seconds')
ylabel('Voltage in Volts')
title('System Output to High Priority loads in State 4')
grid on

```

```

subplot (2,2,2)
plot(x,PL)
xlabel('time in seconds')
ylabel('Voltage in Volts')
title('System Output to Priority loads in State 4')
grid on
subplot (2,2,3)
plot(x,LPL)
xlabel('time in seconds')
ylabel('Voltage in Volts')
title('System Output to Low Priority loads in State 4')
grid on
end
% If (SOLAR is HIGH) and (PUBSUPPLY is LOW) and (AUX is LOW) then
% (HIGH-P is HIGH)(PRIORITY is HIGH)(LOW-P is LOW) (1)
if (SOLAR)== 1 && (PUB_SUP)== 0 && (AUX)== 0
figure
x = 0:0.001:0.08;
HPL = 220*sin(2*pi*50*x);
PL = 220*sin(2*pi*50*x);
LPL = 220*sin(2*pi*50*x);
subplot (2,2,1)
plot(x,PL)
xlabel('time in seconds')
ylabel('Voltage in Volts')
title('System Output to High Priority loads in State 5')
grid on
subplot (2,2,2)
plot(x,PL)
xlabel('time in seconds')
ylabel('Voltage in Volts')
title('System Output to Priority loads in State 5')
grid on
subplot (2,2,3)
x=0;
plot(x,LPL)
xlabel('time in seconds')
ylabel('Voltage in Volts')
title('System Output to Low Priority loads in State 5')
grid on
end
% If (SOLAR is LOW) and (PUBSUPPLY is LOW) and (AUX is LOW) then
% (HIGH-P is HIGH)(PRIORITY is LOW)(LOW-P is LOW) (1)
if (SOLAR)== 0 && (PUB_SUP)== 0 && (AUX)== 0
figure
grid on
x = 0:0.001:0.08;
HPL = 220*sin(2*pi*50*x);
PL = 220*sin(2*pi*50*x);
LPL = 220*sin(2*pi*50*x);

```

```

subplot (2,2,1)
plot(x,HPL)
xlabel('time in seconds')
ylabel('Voltage in Volts')
title('System Output to High Priority loads in State 6')
subplot (2,2,2)
x=0;
plot(x,PL)
xlabel('time in seconds')
ylabel('Voltage in Volts')
title('System Output to Priority loads in State 6')
subplot (2,2,3)
x=0;
plot(x,LPL)
xlabel('time in seconds')
ylabel('Voltage in Volts')
title('System Output to Low Priority loads in State 6')
end
%If (SOLAR is LOW) and (PUBSUPPLY is LOW) and (AUX is HIGH) then
%(HIGH-P is HIGH)(PRIORITY is LOW)(LOW-P is LOW) (1)
if (SOLAR)== 0 && (PUB_SUP)== 0 && (AUX)== 1
figure
grid on
x = 0:0.001:0.08;
HPL = 220*sin(2*pi*50*x);
PL = 220*sin(2*pi*50*x);
LPL = 220*sin(2*pi*50*x);
subplot (2,2,1)
plot(x,HPL)
xlabel('time in seconds')
ylabel('Voltage in Volts')
title('System Output to High Priority loads in State 7')
subplot (2,2,2)
x=0;
plot(x,PL)
xlabel('time in seconds')
ylabel('Voltage in Volts')
title('System Output to Priority loads in State 7')

subplot (2,2,3)
x=0;
plot(x,LPL)
xlabel('time in seconds')
ylabel('Voltage in Volts')
title('System Output to Low Priority loads in State 7')
end
%If (SOLAR is LOW) and (PUBSUPPLY is HIGH) then
%(HIGH-P is HIGH)(PRIORITY is HIGH)(LOW-P is HIGH) (1)
if (SOLAR)== 0 && (PUB_SUP)== 1

```

```

figure
grid on
x = 0:0.001:0.08;
HPL = 220*sin(2*pi*50*x);
PL = 220*sin(2*pi*50*x);
LPL = 220*sin(2*pi*50*x);
subplot (2,2,1)
plot(x,HPL)
xlabel('time in seconds')
ylabel('Voltage in Volts')
title('System Output to High Priority loads in State 8')
subplot (2,2,2)
%x=0;
plot(x,PL)
xlabel('time in seconds')
ylabel('Voltage in Volts')
title('System Output to Priority loads in State 8')
subplot (2,2,3)
%x=0;
plot(x,LPL)
xlabel('time in seconds')
ylabel('Voltage in Volts')
title('System Output to Low Priority loads in State 8')
end
%If (SOLAR is VERYLOW) and (PUBSUPPLY is LOW) and (GEN is LOW) and (AUX is
HIGH) then
%(HIGH-P is HIGH)(PRIORITY is LOW)(LOW-P is LOW) (1)
if (SOLAR)== 0 && (PUB_SUP)== 0 && (GEN)==0 && (AUX) == 1
figure
grid on
x = 0:0.001:0.08;
HPL = 220*sin(2*pi*50*x);
PL = 220*sin(2*pi*50*x);
LPL = 220*sin(2*pi*50*x);
subplot (2,2,1)
plot(x,HPL)
xlabel('time in seconds')
ylabel('Voltage in Volts')
title('System Output to High Priority loads in State 9')
subplot (2,2,2)
x=0;
plot(x,PL)
xlabel('time in seconds')
ylabel('Voltage in Volts')
title('System Output to Priority loads in State 9')
subplot (2,2,3)
x=0;
plot(x,LPL)
xlabel('time in seconds')
ylabel('Voltage in Volts')

```

```

title('System Output to Low Priority loads in State 9')
end
%If (SOLAR is VERYLOW) and (PUBSUPPLY is LOW) and (GEN is HIGH) and (AUX is
LOW) then
%(HIGH-P is HIGH)(PRIORITY is HIGH)(LOW-P is HIGH) (1)
if (SOLAR)== 0 && (PUB_SUP)== 0 && (GEN)== 1 && (AUX) == 0
figure
x = 0:0.001:0.08;
HPL = 220*sin(2*pi*50.*x);
PL = 220*sin(2*pi*50*x);
LPL = 220*sin(2*pi*50*x);
subplot (2,2,1)
plot(x,HPL)
xlabel('time in seconds')
ylabel('Voltage in Volts')
title('System Output to High Priority loads in State 10')
grid on
subplot (2,2,2)
%x=0;
plot(x,PL)
xlabel('time in seconds')
ylabel('Voltage in Volts')
title('System Output to Priority loads in State 10')
subplot (2,2,3)
%x=0;
plot(x,LPL)
xlabel('time in seconds')
ylabel('Voltage in Volts')
title('System Output to Low Priority loads in State 10')
grid on
end
%If (SOLAR is VERYLOW) and (PUBSUPPLY is LOW) and (GEN is LOW) and (AUX is
LOW) then
%(HIGH-P is LOW)(PRIORITY is LOW)(LOW-P is LOW) (1)
if (SOLAR)== 0 && (PUB_SUP)== 0 && (GEN)== 0 && (AUX) == 0
figure
x = 0;
HPL = 220*sin(2*pi*50.*x);
PL = 220*sin(2*pi*50*x);
LPL = 220*sin(2*pi*50*x);
subplot (2,2,1)
plot(x,HPL)
xlabel('time in seconds')
ylabel('Voltage in Volts')
title('System Output to High Priority loads in State 10')
grid on
subplot (2,2,2)
%x=0;
plot(x,PL)
xlabel('time in seconds')

```

```
ylabel('Voltage in Volts')
title('System Output to Priority loads in State 10')
subplot (2,2,3)
%x=0;
plot(x,LPL)
xlabel('time in seconds')
ylabel('Voltage in Volts')
title('System Output to Low Priority loads in State 10')
grid on
end
```

APPENDIX D: ARCHITECTURAL DRAWING OF THE CAMPUS HYBRID MICROGRID



